

South Dakota
Department of Environment
& Natural Resources
Ground Water Quality

Storage Tank Section

South Dakota Department of Environment and Natural Resources

TYPICAL FOUR-TANK STATION

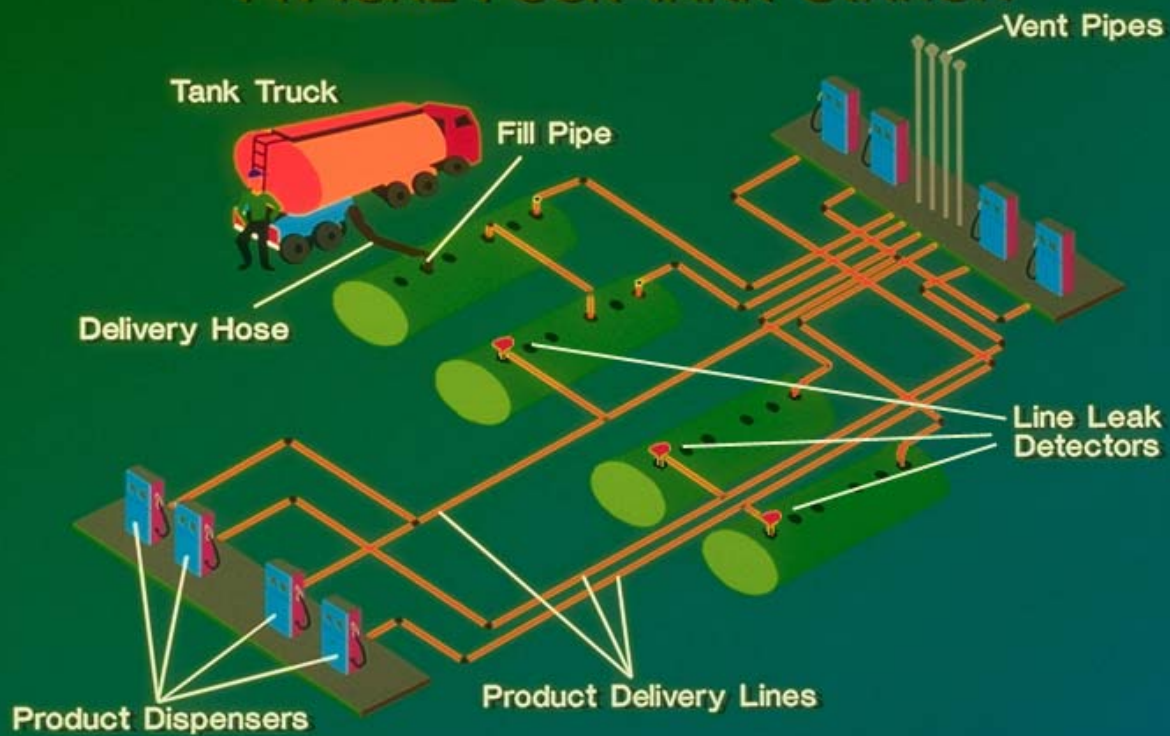

Owners/Operators Guide

This handbook provides a general guidance on the storage tank systems.

For specific requirements look at the underground storage tank system rules
(Chapter 74:56:01 South Dakota Administrative Rules) which are located
at the storage tank program web site. (<http://denr.sd.gov/tanks>)

TABLE OF CONTENTS

A. South Dakota’s Underground Storage Tank Program

- 1- Underground Storage Tank.....04
- 2- Notification..... 04
- 3- Plans and Specifications.....05
- 4- Temporary Closure..... 05
- 5- Permanent Closure..... 06
- 6- Post Closure.....06
- 7- Reporting Spills..... 06

B. Leak Detection.....07

C. Leak Detection System on Tanks

- 1- Automatic Tank Gauging..... 09
- 2- Secondary Containment With Interstitial Monitoring..... 10
- 3- Statistical Inventory Reconciliation (SIR)..... 12
- 4- Vapor Monitoring..... 13
- 5- Groundwater Monitoring (for tanks & piping)..... 14
- 6- Inventory Control And Tank Tightness Testing (for tanks only)..15
- 7- Manual Tank Gauging And Tank Tightness Testing..... 17
- 8- Manual Tank Gauging for tanks 1000 gallon or less..... 18

D. Leak Detection System on Product Lines

- 1- Automatic Line Leak Detection..... 20
- 2- Line Tightness Testing..... 21
- 3- Sump Sensors.....22

E. Leak Prevention Systems..... 23

- 1- What are the basics of spill protection?..... 24
- 2- How do you maintain your spill bucket?.....24
- 3- What are the basics of overfill protection?..... 25
- 4- Spill and overfill checklist..... 26
- 5- Corrosion protection..... 27
- 6- Corrosion protection choices..... 28
- 7- Corrosion protection checklist..... 29
- 8- Record for Periodic Testing of Cathodic Protection Systems.... 30

F. Types of Tanks..... 31

G. Submersible Turbine Pump (STP) and Line leak Detectors..... 33

H. Release Response Important Contact Information..... 34

I. How to Train Operator C.....35

J.	Notification Forms	36
	1- Underground Storage Tank Notification Form.....	37
	2- Aboveground Storage Tank Notification Form.....	42
	3- Change of Ownership Form.....	47
	4- Tank Removal Notification.....	48

A. **South Dakota's Underground Storage Tank Program**

1- **Underground Storage Tank**

South Dakota Department of Environment and Natural Resources (DENR) started regulating underground storage tanks (UST) in 1987.

An underground storage tank system is any tank or combination of tanks, including the underground pipes connected to it, that is used to contain an accumulation of regulated substances, the volume of which, including the volume of the connected underground pipes, is 10 percent or more beneath the surface of the ground.

- The two most exemptions are:
 - ✎ A farm or residential tank of 1,100 gallons or less capacity used for storing motor fuel for non-commercial purposes.
 - ✎ A tank used for storing heating oil for consumptive use on the premises where stored.
- All new underground storage tank systems must have leak detection, spill containment, overfill protection, and must be protected from corrosion when they are installed.
- All new tanks installed within 1,000 feet of an existing community water system or any potable drinking water well must have secondary containment and monitored for leaks.
- All new piping installed within 1,000 feet of an existing community water system or any potable drinking water well must have secondary containment and monitored for leaks and must include under dispenser sumps.
- If over 25 feet of existing piping, located within 1,000 feet of an existing community water system or potable drinking water well is replaced after January 1, 2009, then the entire pipe run must have secondary containment and must include under dispenser sumps. Replaced systems must be designed, constructed and installed to allow for proper leak detection.

2- **Notification**

Within 30 days after installing a new UST or upgrading an existing UST system in accordance with approved plans and specifications, owners or operators must notify the department on a notification form provided by the department.

3- Plans and Specifications

To ensure new tank systems are installed according to state regulations and meet Department of Environment and Natural Resources (DENR) requirements, plans and specifications must be submitted to the Ground Water Quality Program for review and approval at least 30 days before the tanks are installed. If the tank systems meet state standards as described in [ARSD Chapter 74:56:01:04](#) for underground storage tank systems the tank owner should receive an approval letter within 30 days. If insufficient information is submitted DENR will be contacting you.

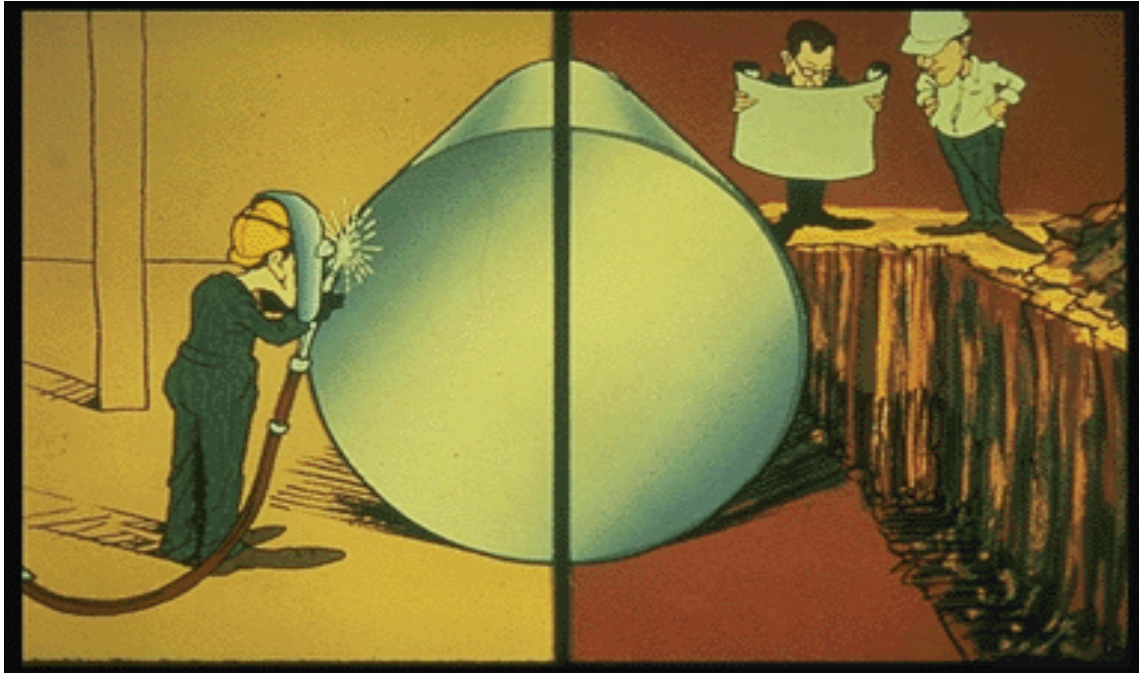

At a minimum, the plans and specifications for Underground Storage Tank Systems must include the type of tank and product line corrosion protection, overfill protection and spill containment specifications, and the method of leak detection for the system. The plans must include all information relevant to show the tank system is in compliance with state rules and must include a site map. Most tank installers will send these plans to DENR for you. You should be aware that other state, federal, and local agencies, including state and local fire prevention authorities, may also need to review the plans. DENR will do periodic inspections of installations. If the work is not being done in accordance with the approved plans and specifications, the work may be halted or required to be redone.

4- Temporary Closure

If an UST system is taken out of service for 3 months or more but less than 12 months and regulated substances are left in the tank, the owner or operator must comply with § 74:56:01:52. Owners or operators must also leave vent lines open and functioning and cap and secure all other lines, pumps, man ways, and ancillary equipment.

5- Permanent Closure

- If an UST system is taken out of service for longer than 12 months, it shall be permanently closed.
- At least 30 days before permanent closure, the owner or operator shall notify the department and assess the excavation area around the UST system for releases. This requirement is satisfied if one of the external monitoring release detection methods allowed under § 74:56:01:24 is in use at the site at the time of closure or if the owner or operator uses:
 - ✎ Portable gas chromatograph mapping, or
 - ✎ Laboratory analysis of soil samples for chemical contamination, or
 - ✎ Laboratory analysis of groundwater for released product, or
 - ✎ An equivalent site assessment method that has been approved by the department.

6- Post Closure

- All tanks that are taken out of service permanently must be emptied and either removed from the ground or filled with an inert solid material.
- Any tank which has been permanently closed may not be brought into use for the storage of regulated substances unless the tank is upgraded to meet new tank standards for design, installation, and release detection.
- Tanks may not be reused for the storage of food or potable water.
- No UST system may be used for the aboveground storage of a regulated substance

7- Reporting Spills

- Each UST owner or operator shall report any spill or overflow of a regulated substance that exceeds its reportable quantity under CERCLA 1980 (40 C.F.R. § 302, July 1, 1990) or threatens the waters of the state and any spill or overflow of petroleum that exceeds 25 gallons or causes a sheen on surface water to the department immediately.
- UST owners or operators shall contain and clean up any spill or overflow of petroleum of 25 gallons or less immediately. If the cleanup is not accomplished within 24 hours, the department or the Division of Emergency Management and applicable local agencies must be notified.

B. LEAK DETECTION

• What Is Release Detection?

You must be able to determine at every 30 days whether or not your tank and piping are leaking by using release detection methods.

Your release detection method must be able to detect a release from any portion of the tank and connected underground piping that routinely contains product.

Release detection must be installed, calibrated, operated, and maintained according to the manufacturer's instructions.

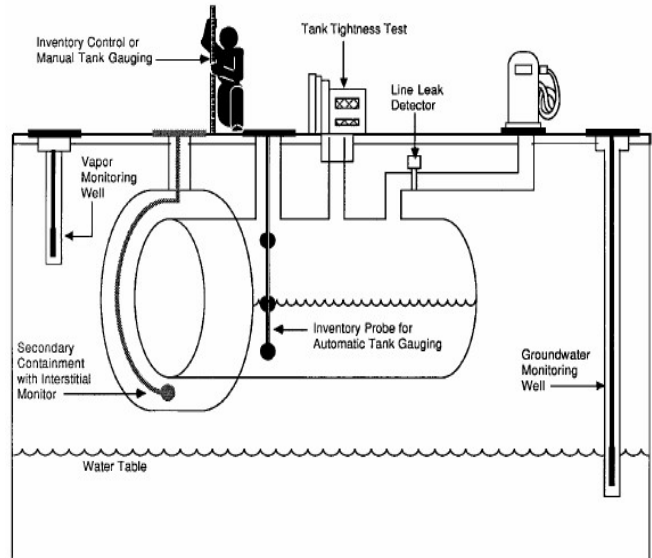

least tank proper

be able of the piping

• Do You Know If Your Release Detection Is Certified To Work At Your UST Site?

Release detection must meet specific performance requirements. You should have documentation from the manufacturer, vendor, or installer of your release detection equipment showing certification that it can meet performance requirements.

Some vendors or manufacturers supply their own certification, but more often an impartial “third party” is paid to test the release detection equipment and certify that performance requirements are met. An independent workgroup of release detection experts periodically evaluates all third-party certifications, thus providing a free and reliable list of evaluations of third-party certifications for various release detection equipment. Frequently updated, this list is available on the Internet at <http://www.nwqlde.org/> (the publication's title is *List Of Leak Detection Evaluations For Underground Storage Tank Systems*). If you can't find the certification anywhere, contact DENR at (605) 773-3296.

By checking the certification, you may discover the method you use has not been approved for use with the type of tank or piping you have or the type of product being stored. For example, you may learn from the certification that your method won't work with manifolded tanks, certain products, high throughput, or with certain tank sizes.

That's why you need to make sure your release detection method has clear certification that it will work effectively at your site with its specific characteristics.

- **How Can You Make Sure Your Leak Detection Method Is Working At Your UST Site?**

If you don't properly understand your Underground Storage Tank (UST) System and your operation and maintenance (O&M) responsibilities, you may allow your UST site to become contaminated — then you will face cleanup costs and associated problems.

To avoid these problems use the checklists on the following pages that describe each type of leak detection method, discuss actions necessary for proper operation and maintenance (O&M), and note the records you should keep.

Locate the methods of release detection you are using at your facility, review these pages, and periodically complete the checklist. You might want to copy a page first and periodically fill out copies later.

If you have questions about your release detection system, review your owner's manual or call the vendor of your system. You may also call DENR at (605) 773-3296.

If you ever suspect or confirm a leak, call DENR at (605) 773-3296. **Never ignore leak detection alarms or failed leak detection tests. Treat them as potential leaks!**

C. LEAK DETECTION SYSTEM ON TANKS

1- Automatic Tank Gauging

Automatic Tank Gauging (ATG) Systems (for tanks only)	
Description Of Release Detection	An automatic tank gauging (ATG) system consists of a probe permanently installed in a tank and wired to a monitor to provide information on product level and temperature. ATG systems automatically calculate the changes in product volume that can indicate a leaking tank.
Certification For Your Release Detection Method	<ul style="list-style-type: none"> ❑ Make sure your ATG system is certified for the types of tanks and stored contents on which the ATG system is used. Most manufacturers have their leak detection devices tested and certified by a third party to verify that their equipment meets specific performance requirements set by DENR. If you don't have certified performance claims, have the manufacturer provide them to you.
Perform These O&M Actions	<ul style="list-style-type: none"> ❑ Use your ATG system to test for leaks at least every 30 days. Most systems are already programmed by the installer to run a leak test periodically. If your system is not programmed to automatically conduct the leak test, refer to your ATG system manual to identify which buttons to push to conduct the leak test. Testing more often than monthly can catch leaks sooner and reduce cleanup costs and problems. ❑ Make sure that the amount of product in your tank is sufficient to run the ATG leak test. The tank must contain a minimum amount of product to perform a valid leak detection test. One source for determining that minimum amount is the certification for your leak detection equipment (as discussed above). ❑ Frequently test your ATG system according to the manufacturer's instructions to make sure it is working properly. Don't assume that your release detection system is working and never needs checking. Read your owner's manual, run the appropriate tests, and see if your ATG system is set up and working properly. Most ATG systems have a test or self-diagnosis mode that can easily and routinely run these checks. ❑ Contact DENR at (605) 773-3296, if your ATG ever fails a test or indicates a release. . ❑ Make sure employees who run, monitor, or maintain the release detection system know exactly what they have to do and to whom to report problems.
Keep These O&M Records	<ul style="list-style-type: none"> ❑ Keep results of your ATG system tests for at least 1 year. Your monitoring equipment may provide printouts that can be used as records. Unless you are recording actual release detection results at least every 30 days and maintaining records for at least 1 year, you are not doing leak detection right. ❑ Keep all records of calibration, maintenance, and repair of your release detection equipment for at least 1 year. ❑ Keep all performance claims supplied by the installer, vendor, or manufacturer for at least 5 years. These records include the certification of your leak detection equipment described above.

2- Secondary Containment With Interstitial Monitoring

Secondary Containment With Interstitial Monitoring (for tanks & piping)	
Description Of Release Detection	Secondary containment is a barrier between the portion of an UST system that contains product and the outside environment. Examples of secondary containment include an outer tank or piping wall, an excavation liner, and a bladder inside an UST. The area between the inner and outer barriers — called the interstitial space — is monitored manually or automatically for evidence of a leak.
Certification For Your Release Detection Method	<ul style="list-style-type: none"> ❑ Make sure your interstitial monitoring equipment and any probes are certified for the types of tanks, piping, and stored contents on which the release detection system is used. Most manufacturers have their leak detection devices tested and certified by a third party to verify that their equipment meets specific performance requirements set by DENR. If you don't have certified performance claims, have the manufacturer provide them to you.
Perform These O&M Actions	<ul style="list-style-type: none"> ❑ Use your release detection system to test for leaks at least every 30 days. Testing more often than monthly can catch leaks sooner and reduce cleanup costs and problems. ❑ Frequently test your release detection system according to the manufacturer's instructions to make sure it is working properly. Don't assume that your release detection system is working and never needs checking. Read your owner's manual, run the appropriate tests, and see if your system is set up and working properly. Some interstitial monitoring systems have a test or self-diagnosis mode that can easily and routinely run these checks. ❑ Contact DENR at (605) 773-3296, if your interstitial monitoring ever fails a test or indicates a release. ❑ Periodically have a qualified UST contractor, such as the vendor who installed your release detection system, service all the system components according to the manufacturer's service instructions. Tank probes and other components can wear out and must be checked periodically. Many vendors recommend or require this maintenance activity at least annually. ❑ Keep interstitial monitoring access ports clearly marked and secured. ❑ Check your interstitial monitoring system owner's manual often to answer questions and to make sure you know the system's O&M procedures. Call the system's vendor or manufacturer for a copy of the owner's manual if you don't have one. ❑ Make sure employees who run, monitor, or maintain the release detection system know exactly what they have to do and to whom to report problems.
Keep These O&M Records	<ul style="list-style-type: none"> ❑ Keep results of your release detection system tests for at least 1 year. Your monitoring equipment may provide printouts that can be used as records. Unless you are recording actual release detection results at least every 30 days and maintaining records for at least 1 year, you are not doing leak detection right. ❑ Keep all records of calibration, maintenance, and repair of your release detection equipment for at least 1 year. ❑ Keep all performance claims supplied by the installer, vendor, or manufacturer for at least 5 years. These records include the certification of your leak detection equipment described above.

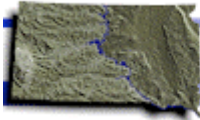

INTERSTITIAL MONITORING LOG

MONTHLY LOG FOR YEAR _____

For Sumps and Tank Interstitial Space (if applicable): Designate "P" for product, "W" for water, "P" and "W" for both, and "D" for dry. If "P" or "W" or both are indicated, include depth of each in inches. Questions on how to complete this form should be directed to the Storage Tank Section at (605) 773-3296

Facility Name:

Address:

City, State, Zip Code:

Facility I.D. Number:

Tank System Information

Tank Number:

Type of Product in Tank:

Tank Size:

Double Wall Piping, circle one: (Yes) (No)

Tank Material, circle one: (Steel) (Fiberglass)

Piping Material, circle one: (Steel) (Plastic) (Fiberglass)

Month	Date Monitored	Monitor's Initials	Tank Interstitial Space	Piping Sump #1	Piping Sump #2 (if applicable)	Dispenser Sump (if applicable)
January						
February						
March						
April						
May						
June						
July						
August						
September						
October						
November						
December						

Date of any Repairs or Tightness Tests

Description of any Repairs or Tightness Tests

Comments

(Include information on liquid removal and disposal from sumps, if applicable.)

3- Statistical Inventory Reconciliation (SIR)

Statistical Inventory Reconciliation (SIR) (for tanks & piping)	
Description Of Release Detection	<p>SIR is typically a method in which a trained professional uses sophisticated computer software to conduct a statistical analysis of inventory, delivery, and dispensing data. You must supply the professional with data every month. There are also computer programs that enable an owner/operator to perform SIR. In either case, the result of the analysis may be pass, inconclusive, or fail.</p>
Certification For Your Release Detection Method	<ul style="list-style-type: none"> ❑ Make sure your SIR vendor’s methodology is certified for the types of tanks, piping, and product on which you use SIR. Most vendors have their leak detection methodology tested and certified by a third party to verify that their equipment meets specific performance requirements.
Perform These O&M Actions	<ul style="list-style-type: none"> ❑ Supply daily inventory data to your SIR vendor (as required) at least every 30 days. The vendor will provide you with your leak detection results after the statistical analysis is completed. Otherwise, use your computer software at least every 30 days to test your tank for leaks. ❑ Contact DENR at (605) 773-3296, if your UST system fails a leak test. ❑ If you receive an inconclusive result, you must work with your SIR vendor to correct the problem and document the results of the investigation. An inconclusive result means that you have not performed leak detection for that month. If you cannot resolve the problem, treat the inconclusive result as a suspected release. ❑ If you stick your tank to gather data for the SIR vendor or your software, make sure your stick can measure to one-eighth of an inch and can measure the level of product over the full range of the tank’s height. You should check your measuring stick periodically to make sure you can read the markings and numbers and that the bottom of the stick is not worn. ❑ Make sure employees who run, monitor, or maintain the release detection system know exactly what they have to do and to whom to report problems.
Keep These O&M Records	<ul style="list-style-type: none"> ❑ Keep results of your SIR tests for at least 1 year. Unless you are keeping records of the 30-day release detection results and maintaining those records for at least 1 year, you are not doing leak detection right. ❑ Keep all vendor performance claims for at least 5 years. This includes the certification of the SIR method discussed above. ❑ If you use an ATG system, keep all records of calibration, maintenance, and repair of your release detection equipment for at least 1 year. ❑ Keep the records of investigations conducted as a result of any monthly monitoring conclusion of inconclusive or fail for at least 1 year. This may include the results of a tightness test performed during the investigation or a re-evaluation based on corrected delivery or dispenser data.

4. Vapor Monitoring

Vapor Monitoring (for tanks & piping)	
Description Of Release Detection	<p>Vapor monitoring measures product vapors in the soil at the UST site to check for a leak. A site assessment must determine the number and placement of monitoring wells that make sure a release is detected. NOTE: vapor monitors will not work well with substances that do not easily vaporize (such as diesel fuel).</p>
Certification For Your Release Detection Method	<ul style="list-style-type: none"> ❑ Make sure your vapor monitoring equipment is certified for the types of stored contents on which the release detection system is used. Most manufacturers have their leak detection devices tested and certified by a third party to verify that their equipment meets specific performance requirements.
Perform These O&M Actions	<ul style="list-style-type: none"> ❑ Use your release detection system to test for leaks at least every 30 days. Testing more often than monthly can catch leaks sooner and reduce cleanup costs and problems. Be sure you check all of your vapor monitoring wells. ❑ Contact DENR at (605) 773-3296, if your UST system fails a leak test. ❑ Frequently test your release detection system according to the manufacturer's instructions to make sure it is working properly. Don't assume that your release detection system is working and never needs checking. Some electronic vapor monitoring systems have a test or self-diagnosis mode. If you have components (such as monitoring equipment, probes or sensors) for your vapor monitoring system, read your manual and test your equipment to see if it is working properly. ❑ Periodically have a qualified UST contractor, such as the vendor who installed your release detection system, service all the system components according to the manufacturer's service instructions. Probes and other components can wear out and must be checked periodically. Many vendors recommend or require this maintenance activity at least annually. ❑ Keep your vapor monitoring wells clearly marked and secured. ❑ Check your vapor monitoring system owner's manual often to answer questions and to make sure you know the system's operation and maintenance procedures. Call the system's vendor or manufacturer for a copy of the owner's manual if you don't have one. ❑ Make sure employees who run, monitor, or maintain the release detection system know exactly what they have to do and to whom to report problems.
Keep These O&M Records	<ul style="list-style-type: none"> ❑ Keep results of your release detection system tests for at least 1 year. Your monitoring equipment may provide printouts that can be used as records. Unless you are recording actual release detection results at least every 30 days and maintaining records for at least 1 year, you are not doing leak detection right. ❑ Keep all records of calibration, maintenance, and repair of your release detection equipment for at least 1 year. ❑ Keep all performance claims supplied by the installer, vendor, or manufacturer for at least 5 years. These records include the certification of your leak detection equipment described above.

5- Groundwater Monitoring (for tanks & piping)

Groundwater Monitoring (for tanks & piping)	
Description Of Release Detection	Groundwater monitoring looks for the presence of liquid product floating on the groundwater at the UST site. A site assessment must determine the number and placement of monitoring wells that make sure a release is detected. NOTE: this method cannot be used at sites where groundwater is more than 20 feet below the surface.
Certification For Your Release Detection Method	<ul style="list-style-type: none"> ❑ Make sure any automated groundwater monitoring equipment is certified for the types of stored contents on which the release detection system is used. Most manufacturers have their leak detection devices tested and certified by a third party to verify that their equipment meets specific performance requirements set by DENR. If you don't have certified performance claims, have the manufacturer provide them to you.
Perform These O&M Actions	<ul style="list-style-type: none"> ❑ Use your release detection system to test for leaks at least every 30 days. Testing more often than monthly can catch leaks sooner and reduce cleanup costs and problems. Be sure you check all of your groundwater monitoring wells. ❑ Contact DENR at (605) 773-3296, if your UST system fails a leak test. ❑ Frequently test your automated release detection system according to the manufacturer's instructions to make sure it is working properly. Don't assume that your release detection system is working and never needs checking. Some electronic groundwater monitoring systems have a test or self-diagnosis mode. If you have components (such as monitoring equipment, probes or sensors) for your groundwater monitoring system, read your manual and test your equipment to see if it is working properly. ❑ Periodically have a qualified UST contractor, such as the vendor who installed your release detection system, service all the system components according to the manufacturer's service instructions. Probes and other components can wear out and must be checked periodically. Many vendors recommend or require this maintenance activity at least annually. ❑ Keep your groundwater monitoring wells clearly marked and secured. ❑ Check your groundwater monitoring system owner's manual often to answer questions and to make sure you know the system's operation and maintenance procedures. Call the system's vendor or manufacturer for a copy of the owner's manual if you don't have one. ❑ Make sure employees who run, monitor, or maintain the release detection system know exactly what they have to do and to whom to report problems.
Keep These O&M Records	<ul style="list-style-type: none"> ❑ Keep results of your release detection system tests for at least 1 year. Your monitoring equipment may provide printouts that can be used as records. Unless you are recording actual release detection results at least every 30 days and maintaining records for at least 1 year, you are not doing leak detection right. ❑ Keep all records of calibration, maintenance, and repair of your release detection equipment for at least 1 year. <p>Keep all performance claims supplied by the installer, vendor, or manufacturer for at least 5 years. These records include the certification of your leak detection equipment described above.</p>

6- Inventory Control And Tank Tightness Testing (for tanks only)

Inventory Control And Tank Tightness Testing (for tanks only)	
Description Of Release Detection	<p>This temporary method combines monthly inventory control with periodic tank tightness testing. Inventory control involves taking measurements of tank contents and recording the amount of product pumped each operating day, measuring and recording tank deliveries, and reconciling all this data at least once a month. This combined method also includes tightness testing, a sophisticated test performed by trained professionals.</p> <p><i>NOTE: This combination method can only be used temporarily for up to 10 years after installing a new UST or for up to 10 years after your tank meets the corrosion protection requirements.</i></p>
Certification For Your Release Detection Method	<ul style="list-style-type: none"> <input type="checkbox"/> Make sure your tank tightness testing method is certified for the types of tanks and stored contents on which the tightness test is used. Most tightness test methods are certified by a third party to verify that they meet specific performance requirements set by DENR. If you don't have certified performance claims, have the tightness tester provide them to you.
Perform These O&M Actions	<ul style="list-style-type: none"> <input type="checkbox"/> Take inventory readings and record the numbers at least each day that product is added to or taken out of the tank. You may want to use the Daily Inventory Worksheet provided for you on the next page. <input type="checkbox"/> Reconcile the fuel deliveries with delivery receipts by taking inventory readings before and after each delivery. Record these readings on a Daily Inventory Worksheet. <input type="checkbox"/> Reconcile all your data at least every 30 days. Use a Monthly Inventory. <input type="checkbox"/> Have a tank tightness test conducted at least every 5 years. This testing needs to be conducted by a professional trained in performing tank tightness testing. <input type="checkbox"/> Contact DENR at (605) 773-3296, if your tank fails a tightness test or if fails two consecutive months of inventory control. <input type="checkbox"/> Ensure that your measuring stick can measure to the nearest one-eighth inch and can measure the level of product over the full range of the tank's height. You should check your measuring stick periodically to make sure that you can read the markings and numbers and that the bottom of the stick is not worn. <input type="checkbox"/> Measure the water in your tank to the nearest one-eighth inch at least once a month and record the results on the reconciliation sheet. You can use a paste that changes color when it comes into contact with water. <input type="checkbox"/> Make sure employees who run, monitor, or maintain the release detection system know exactly what they have to do and to whom to report problems.
Keep These O&M Records	<ul style="list-style-type: none"> <input type="checkbox"/> Keep results of your release detection system tests for at least 1 year. Your monitoring equipment may provide printouts that can be used as records. Unless you are recording actual release detection results at least every 30 days and maintaining records for at least 1 year, you are not doing leak detection right. <input type="checkbox"/> Keep the results of your most recent tightness test. <input type="checkbox"/> Keep all certification and performance claims for tank tightness test performed at your UST site for at least 5 years.

Monthly Inventory Record

Month/Year : _____ / _____ Tank Identification & Type Of Fuel: _____

Date Of Water Check: _____ Level (Inches): _____ Facility Name: _____

Date	Start Stick Inventory (Gallons)	Gallons Delivered	Gallons Pumped	Book Inventory (Gallons)	End Stick Inventory		Daily Over (+) Or Short () [End Book]	Initials
					(Inches)	(Gallons)		
1	(+)	(-)	(=)					
2	(+)	(-)	(=)					
3	(+)	(-)	(=)					
4	(+)	(-)	(=)					
5	(+)	(-)	(=)					
6	(+)	(-)	(=)					
7	(+)	(-)	(=)					
8	(+)	(-)	(=)					
9	(+)	(-)	(=)					
7	(+)	(-)	(=)					
8	(+)	(-)	(=)					
9	(+)	(-)	(=)					
10	(+)	(-)	(=)					
11	(+)	(-)	(=)					
12	(+)	(-)	(=)					
13	(+)	(-)	(=)					
14	(+)	(-)	(=)					
15	(+)	(-)	(=)					
16	(+)	(-)	(=)					
17	(+)	(-)	(=)					
18	(+)	(-)	(=)					
19	(+)	(-)	(=)					
20	(+)	(-)	(=)					
21	(+)	(-)	(=)					
22	(+)	(-)	(=)					
23	(+)	(-)	(=)					
24	(+)	(-)	(=)					
25	(+)	(-)	(=)					
26	(+)	(-)	(=)					
27	(+)	(-)	(=)					
28	(+)	(-)	(=)					
29	(+)	(-)	(=)					
30	(+)	(-)	(=)					
31	(+)	(-)	(=)					

Total Gallons Pumped >

Total Gallons Over Or Short >

Leak Check: Drop the last two digits from the **Total Gallons Pumped** number and enter here: _____ + 130 = _____ gallons
 Compare these numbers

Is the total gallons over or short **larger** than leak check result? **Yes No** (circle one)
 If your answer is Yes for 2 months in a row, **notify DENR** as soon as possible.

Keep This Piece Of Paper On File For At Least 1 Year

7- Manual Tank Gauging And Tank Tightness Testing

(for tanks 2,000 gallons or less only)

Manual Tank Gauging And Tank Tightness Testing (for tanks 2,000 gallons or less only)	
Description Of Release Detection	<p>This temporary method combines manual tank gauging with periodic tank tightness testing. <u>It may be used only for tanks of 2,000 gallons or less capacity.</u> Manual tank gauging involves taking your tank out of service for the testing period (at least 36 hours) each week, during which the contents of the tank are measured twice at the beginning and twice at the end of the test period. The measurements are then compared to weekly and monthly standards to determine if the tank is tight. This combined method also includes tightness testing, a sophisticated test performed by trained professionals.</p> <p><i>NOTE: This combination method can only be used temporarily for up to ten years after installing a new</i></p>
Certification For Your Release Detection Method	<ul style="list-style-type: none"> <input type="checkbox"/> Make sure your tank tightness testing is certified for the types of tanks and stored contents on which the tightness test is used. Most tightness test methods are certified by a third party to verify that they meet specific performance requirements set by DENR. If you don't have certified performance claims, have the tightness tester provide them to you.
Perform These O&M Actions	<ul style="list-style-type: none"> <input type="checkbox"/> Once a week, record two inventory readings at the beginning of the test, allow the tank to sit undisturbed for the time specified in the Manual Tank Gauging and record two inventory readings at the end of the test <input type="checkbox"/> Reconcile the numbers weekly and record them on a Manual Tank Gauging Record. <input type="checkbox"/> Contact DENR at (605) 773-3296, if your tank fails the weekly standard. <input type="checkbox"/> At the end of 4 weeks, reconcile your records for the monthly standard and record the result on a Manual Tank Gauging Record. <input type="checkbox"/> Contact DENR at (605) 773-3296, if your tank fails the monthly standard. <input type="checkbox"/> Conduct a tank tightness test at least every 5 years. This testing needs to be conducted by a professional trained in performing tank tightness testing. <input type="checkbox"/> Contact DENR at (605) 773-3296, if your tank fails the tightness test. <input type="checkbox"/> Ensure that your measuring stick can measure to the nearest one-eighth inch and can measure the level of product over the full range of the tank's height. You should check your measuring stick periodically to make sure that you can read the markings and numbers and that the bottom of the stick is not worn. <input type="checkbox"/> Make sure employees who run, monitor, or maintain the release detection system know exactly what they have to do and to whom to report problems.
Keep These O&M Records	<ul style="list-style-type: none"> <input type="checkbox"/> Keep your manual tank gauging records for at least 1 year. Unless you are recording actual release detection results at least weekly and every 30 days and maintaining records for at least 1 year, you are not doing leak detection right. <input type="checkbox"/> Keep the results of your most recent tightness test. <input type="checkbox"/> Keep all certification and performance claims for tank tightness test performed at your UST site for at least 5 years.

8- **Manual Tank Gauging**
(for tanks 1,000 gallons or less only)

Manual Tank Gauging (for tanks 1,000 gallons or less only)	
Description Of Release Detection	<u>This method may be used only for tanks of 1,000 gallons or less capacity</u> meeting certain requirements. These requirements (tank size, tank dimension, and test time) are found in the manual tank gauging record on the next page. Manual tank gauging involves taking your tank out of service for the testing period (at least 36 hours) each week, during which time the contents of the tank are measured twice at the beginning and twice at the end of the test period. The measurements are then compared to weekly and monthly standards to determine if the tank is tight.
Have Certification For Your Release Detection Method	None required.
Perform These O&M Actions	<ul style="list-style-type: none"> <input type="checkbox"/> Once a week, record two inventory readings at the beginning of the test, allow the tank to sit undisturbed for the time specified in the Manual Tank Gauging Record on the next page, and record two inventory readings at the end of the test (use any form comparable to the one on the following page). <input type="checkbox"/> Reconcile the numbers weekly and record them on a Manual Tank Gauging Record (see the next page). <input type="checkbox"/> Call DENR if your tank fails the weekly standard. <input type="checkbox"/> At the end of 4 weeks, reconcile your records for the monthly standard and record the result on a Manual Tank Gauging Record (see the next page). <input type="checkbox"/> Call DENR if your tank fails the monthly standard. <input type="checkbox"/> Ensure that your measuring stick can measure to the nearest one-eighth inch and can measure the level of product over the full range of the tank's height. You should check your measuring stick periodically to make sure that you can read the markings and numbers and that the bottom of the stick is not worn. <input type="checkbox"/> Make sure employees who run, monitor, or maintain the release detection system know exactly what they have to do and to whom to report problems. Develop and maintain regular training programs for all employees.
Keep These O&M Records	<ul style="list-style-type: none"> <input type="checkbox"/> Keep your manual tank gauging records for at least 1 year. Unless you are recording actual release detection results weekly and at least every 30 days and maintaining records for at least 1 year, you are not doing leak detection right.

Manual Tank Gauging

Month/Year : _____/_____

Tank Identification & Type Of Fuel: _____

Date Of Water Check: _____ Level (Inches): _____ Facility Name: _____

YEAR: ____ START DATE (MONTH/DAY)	LENGTH OF TEST (HOURS)	START		END		CHANGE IN VOLUME (WEEKLY)	PASS WEEKLY TEST	CHANGE IN VOLUME (MONTHLY AVERAGE)	PASS MONTHLY TEST
		AVE INCH	GAL	AVE INC	GAL				
							Y N		
							Y N		Y N
							Y N		
							Y N		
							Y N		
							Y N		Y N
							Y N		
							Y N		
							Y N		
							Y N		Y N
							Y N		
							Y N		
							Y N		
							Y N		Y N
							Y N		
							Y N		
							Y N		

Table of Test Standards for Manual Tank Gauging

Tank Size	Minimum Duration Of Test	Weekly Standard (1 test)	Monthly Standard (4-test average)
up to 550 gallons	36 hours	10 gallons	5 gallons
551-1,000 gallons (when tank diameter is 64")	44 hours	9 gallons	4 gallons
551-1,000 gallons (when tank diameter is 48")	58 hours	12 gallons	6 gallons
1,001-2,000 gallons (also requires periodic tank tightness testing)	36 hours	26 gallons	13 gallons

D. LEAK DETECTION SYSTEM ON PRODUCT LINES

1- Automatic Line Leak Detection

Automatic Line Leak Detection (for pressurized piping only)	
Description Of Release Detection	<p>Automatic line leak detectors (LLDs) are designed to detect a catastrophic release from pressurized piping. Automatic LLDs must be designed to detect a leak at least as small as 3 gallons per hour at a line pressure of 10 psi within 1 hour. When a leak is detected, automatic LLDs must shut off the product flow, restrict the product flow, or trigger an audible or visual alarm. NOTE: Mechanical automatic LLDs need to be installed and operated as close as possible to the tank (LLDs are designed to detect a leak, restrict flow, etc. only between the detector and the dispenser).</p>
Certification For Your Release Detection Method	<ul style="list-style-type: none"> ❑ Make sure your release detection equipment is certified for the types of piping and stored contents on which the release detection system is used. Most manufacturers have their leak detection devices tested and certified by a third party to verify that their equipment meets specific performance requirements set by DENR. If you don't have certified performance claims, have the manufacturer provide them to you.
Perform These O&M Actions	<ul style="list-style-type: none"> ❑ Frequently test your automatic LLDs according to the manufacturer's instructions to make sure it is working properly. Don't assume that your release detection system is working and never needs checking. Some monitoring systems have a test or self-diagnosis mode. ❑ Periodically have a qualified UST contractor, such as the vendor who installed your release detection system, service all the system components according to the manufacturers' service instructions. Components can wear out and must be checked periodically. Many vendors recommend or require this maintenance activity at least annually. ❑ Contact DENR at (605) 773-3296, if your LLD detects a leak. ❑ Make sure employees who run, monitor, or maintain the release detection system know exactly what they have to do and to whom to report problems.
Keep These O&M Records	<ul style="list-style-type: none"> ❑ For at least a year, keep the annual test that demonstrates that the LLD is functioning properly. ❑ If used for monthly monitoring, keep results of your release detection system tests for at least 1 year. Your monitoring equipment system may provide printouts that can be used as records. Unless you are recording actual release detection results at least every 30 days and maintaining records for at least 1 year, you are not doing leak detection right. ❑ Keep all records of calibration, maintenance, and repair of your release detection equipment for at least 1 year. ❑ Keep all performance claims supplied by the installer, vendor, or manufacturer for at least 5 years. These records include the certification of your leak detection equipment described above.

2- Line Tightness Testing

Line Tightness Testing (for piping only)	
Description Of Release Detection	<p>This method uses a periodic line tightness test to determine if your piping is leaking. Tightness testing can be performed by either a trained professional or by using a permanently installed electronic system (sometimes connected to an automatic tank gauging system).</p>
Certification For Your Release Detection Method	<ul style="list-style-type: none"> ❑ Make sure your line tightness testing or permanently installed electronic system is certified for the types of piping and stored contents on which the release detection system is used. Most tightness test methods and release detection equipment have been tested and certified by a third party to verify that the equipment or services meet specific performance requirements set by DENR. If you don't have certified performance claims, have the tightness tester or equipment manufacturer provide them to you.
Perform These O&M Actions	<ul style="list-style-type: none"> ❑ If line tightness testing is used for pressurized piping, the test must be conducted at least annually. ❑ If line tightness testing is used for suction piping (with check valve), the test must be conducted at least every three years. Safe suction piping (no check valve) does not need tightness testing. ❑ This tightness testing must be conducted by a professional trained in performing line tightness testing or by using a permanently installed electronic system. ❑ Contact DENR at (605) 773-3296, if your piping fails the tightness test or if the electronic system indicates a leak. ❑ Periodically have a qualified UST contractor, such as the vendor who installed your release detection system, service all the system components according to the manufacturers' service instructions. Components can wear out and must be checked periodically. Many vendors recommend or require this maintenance activity at least annually. ❑ Make sure employees who run, monitor, or maintain the release detection system know exactly what they have to do and to whom to report problems.
Keep These O&M Records	<ul style="list-style-type: none"> ❑ Keep results of your release detection system tests for at least 1 year. Your monitoring equipment may provide printouts that can be used as records. Unless you are recording actual release detection results at least every 30 days and maintaining records for at least 1 year, you are not doing leak detection right. ❑ If you use a permanently installed electronic system, keep all records of calibration, maintenance, and repair of your equipment for at least 1 year. ❑ Keep all performance claims supplied by the installer, vendor, or manufacturer for at least 5 years. These records include the certification of your leak detection equipment described above.

3- Sump Sensor If you have double wall piping, you may find a sump sensor like the two pictured here below. You will need to check the sump sensors annually to make sure they are working properly. You will also need to check the sumps monthly to make sure they are tight and sealed. Below is the check list for your monthly inspections.



Choose yes or no below for each question that applies. Choosing no on any item indicates a problem that should be corrected.

Turbine/Transition/Intermediate Sumps	Sump No.: _____			Sump No.: _____			Sump No.: _____			Sump No.: _____		
	Yes	No	Fixed?	Yes	No	Fixed?	Yes	No	Fixed?	Yes	No	Fixed?
Are The Lids Tight And Sealed Correctly?												
Are The Sump Walls Intact?												
Is The Sump Free Of Debris, Liquid, Or Ice?												
Is The Sump Free Of Cracks Or Holes?*												
Are Sump Components Leak-Free (No Leak Or Drips)?												
Is The Sump Free Of Staining/New Staining?												
Are The Sensors Positioned Correctly?*												
Are All Penetrations Into The Sump In Good Condition?*												
Are The Test Boots Positioned Correctly / In Good Condition?*												
Is The Piping And Other Equipment In Good Condition?												
Dispenser Sumps	Dispenser No.: __			Dispenser No.: __			Dispense No.: __			Dispenser No.: __		
	Yes	No	Fixed?	Yes	No	Fixed?	Yes	No	Fixed?	Yes	No	Fixed?
Is The Sump Free Of Debris, Liquid, Or Ice In The Sump?												
Is The Sump Free Of Cracks Or Holes?												
Are Sump Components Leak-Free (No Leak Or Drips)?												
Is The Sump Free Of Staining/New Staining?												
Are The Sensors Positioned Correctly?												
Are All Penetrations Into The Sump In Good Condition?												
Are The Test Boots Positioned Correctly / In Good Condition?												
Is The Piping And Other Equipment In Good Condition?												

In case of a leak call DENR at (605) 773-3296

E. LEAK PREVENTION

- The purpose of leak prevention equipments namely spill, overflow and corrosion protection is to eliminate the potential for a release. The equipment must be in working order and used properly to provide adequate protection from spills, overfills and corrosion.
- Even the best spill and overflow protection equipment can become faulty over time if not properly operated and maintained.
- Only one gallon of fuel leaking each week from a poorly maintained spill bucket can result in up to 195 tons of contaminated soil in a year.
- Improper maintenance of the spill bucket at the UST site pictured below contributed to significant contamination of soil and groundwater.

Spill Bucket

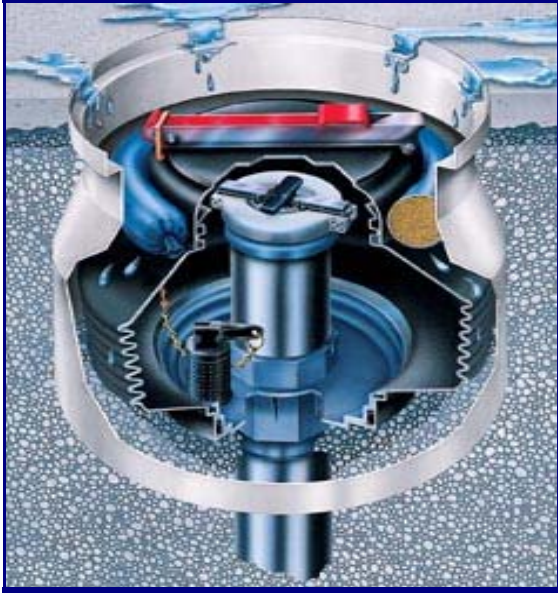

Overfill Protection



Corrosion Protection

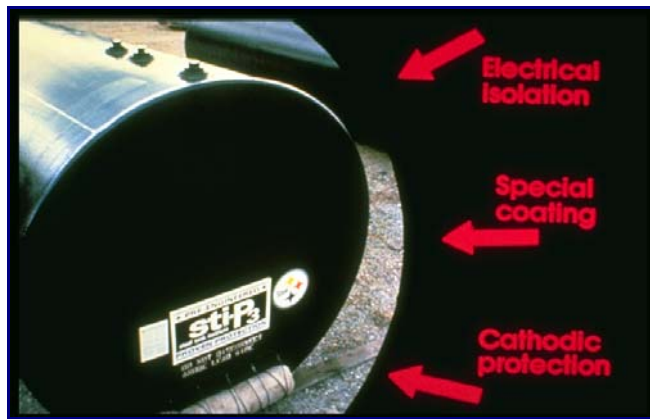

1- What are the basics of spill protection?

Your USTs must have catchment basins — also called spill buckets — installed at the fill pipe to contain spills that may occur as a result of fuel deliveries.

- ✎ The spill bucket is designed to temporarily contain product spills that might occur during fuel delivery. To contain a spill, the spill bucket must be liquid tight.
- ✎ **The spill bucket is not designed to contain fuel for long periods of time.** After each delivery, empty and dispose of contents properly.
- ✎ Spill buckets need to be large enough to contain any fuel that may spill when the delivery hose is uncoupled from the fill pipe. Spill buckets typically range in size from 5 gallons to 25 gallons.

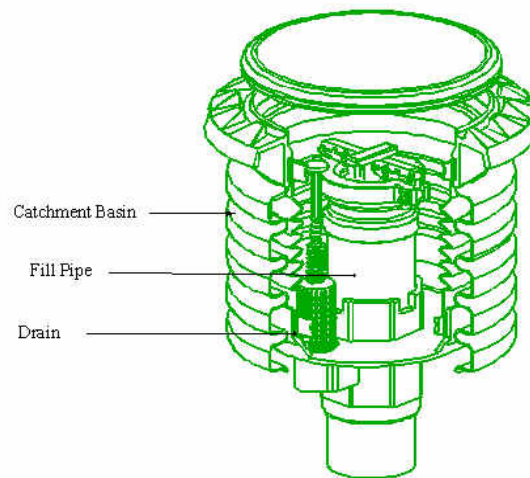

2. How do you maintain your spill bucket?

The checklist below provides information on properly maintaining your spill bucket.

Spill Bucket Checklist

- Keep your spill bucket empty of liquids.**
Some spill buckets are equipped with a valve that allows you to drain accumulated fuel into your UST. Others may be equipped with a manual pump so fuel can be put into your UST by pumping it through the fill pipe. However, keep in mind that when you pump out or drain your spill bucket into your UST, any water and debris may also enter the UST. If a basin is not equipped with drain valve or pump, then any accumulated fuel or water must be removed manually and disposed of properly.
- Periodically check your spill bucket to remove any debris.**
Debris could include soil, stones, or trash.
- Periodically check to see if your spill bucket is still liquid tight.**
Have a qualified UST contractor inspect your spill bucket for signs of wear, cracks, or holes. Based on this inspection, the contractor may suggest a test to determine if the spill bucket is tight or needs repair or replacement.

3- What are the basics of overfill protection?

- Your USTs must have overfill protection installed to help prevent the overfilling of tanks. Three types of overfill protection devices are commonly used:

- ✎ Automatic shutoff devices
- ✎ Overfill alarms
- ✎ Ball float valves

- Each of these forms of overfill protection is discussed in detail on the following pages.

- **How can you help the delivery person avoid overfills?**
To protect your business, you must make every effort to help the delivery person avoid overfilling your UST.

- **Use a checklist on correct filling practices**

- If correct filling practices are used, you will not exceed the UST's capacity. Overfills are caused when the delivery person makes a mistake, such as ignoring an overfill alarm.

- **Use signs, alert your delivery person**

- The delivery person should know what type of overfill device is present on each tank at your facility and what action will occur if the overfill device is triggered — such as a visual and/or audible alarm or that the product flow into the tank will stop or slow significantly.

Educate and alert your delivery person by placing a clear sign near your fill pipes, in plain view of the delivery person.

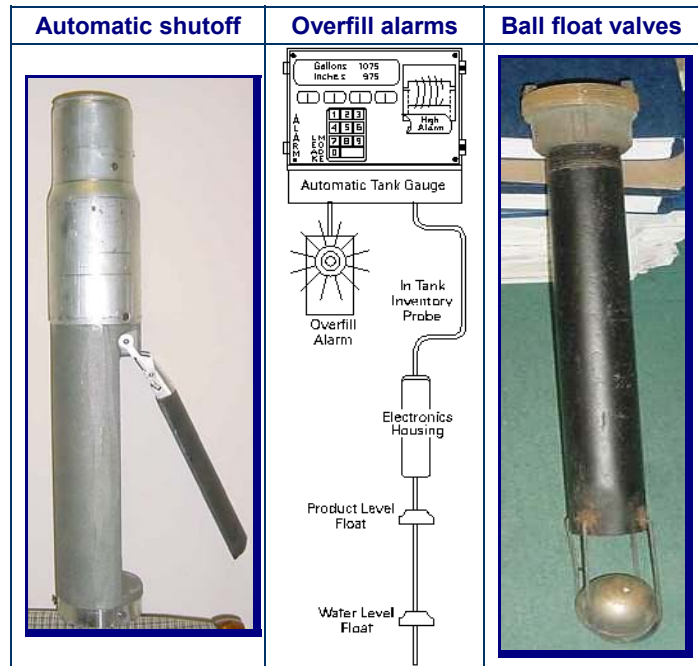

4- Spill and overfill checklist

Spill And Overfill Checklist	
Spill Bucket	<ul style="list-style-type: none"> ❑ Keep your spill bucket empty of liquids. Some spill buckets are equipped with a drainage valve which allows you to drain accumulated fuel into your UST. Others can be equipped with a manual pump so fuel can be put into your UST by pumping it through the fill pipe. However, keep in mind that when you pump out or drain your spill bucket into your UST, any water and debris may also enter the UST. If a spill bucket is not equipped with a drain valve or pump, then any accumulated fuel or water must be removed manually and disposed of properly. ❑ Periodically check to see if your spill bucket is still liquid tight. Have a qualified UST contractor inspect your spill bucket for signs of wear, cracks, or holes. Based on this inspection, the contractor may suggest a test to determine if the spill bucket is tight or needs repair or replacement.
Automatic Shutoff Devices	<ul style="list-style-type: none"> ❑ A qualified UST contractor periodically checks to make sure that the automatic shutoff device is functioning properly and that the device will shut off fuel flowing into the tank at 95% of the tank capacity or before the fittings at the top of the tank are exposed to fuel: <ul style="list-style-type: none"> • Make sure the float operates properly. • Make sure that there are no obstructions in the fill pipe that would keep the floating mechanism from working. ❑ You have posted signs that the delivery person can easily see and that alert the delivery person to the overfill warning devices and alarms in use at your facility.
Overfill Alarms	<ul style="list-style-type: none"> ❑ A qualified UST contractor periodically checks your electronic overfill alarm to make sure that it is functioning properly and that the alarm activates when the fuel reaches 90% of the tank capacity or is within one minute of being overfilled: <ul style="list-style-type: none"> • Ensure that the alarm can be heard and/or seen from where the tank is fueled. • Make sure that the electronic device and probe are operating properly. ❑ You have posted signs that the delivery person can easily see and that alert the delivery person to the overfill warning devices and alarms in use at your facility.
Ball Float Valves	<ul style="list-style-type: none"> ❑ A qualified UST contractor periodically checks to make sure that the ball float valve is functioning properly and that it will restrict fuel flowing into the tank at 90% of the tank capacity or 30 minutes prior to overfilling: <ul style="list-style-type: none"> • Ensure that the air hole is not plugged. • Make sure the ball cage is still intact. • Ensure the ball still moves freely in the cage. • Make sure the ball still seals tightly on the pipe. ❑ You have posted signs that the delivery person can easily see and that alert the delivery person to the overfill warning devices and alarms in use at your facility.

5- Corrosion protection

To prevent leaks, all parts of your UST system that are underground and routinely contain product need to be protected from corrosion. The UST system includes the tank, piping, and ancillary equipment, such as flexible connectors, fittings, and pumps. Unprotected metal UST components can deteriorate and leak when underground electrical currents act upon them.

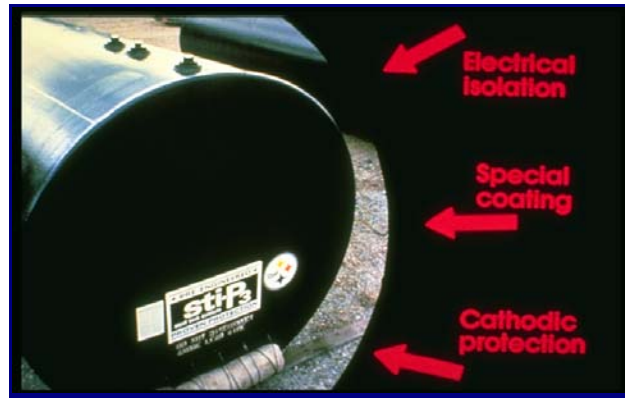

One way to protect UST components from corrosion is to **make them with nonmetallic, noncorrodible materials**, such as fiberglass reinforced plastic (FRP) or USTs made of (or clad or jacketed with) other noncorrodible materials.

UST components made from metal, that routinely contain product and are in direct contact with the ground need corrosion protection provided by cathodic protection or (in some cases) lining the interior of the tank, as described below. These options require operation and maintenance (O&M).

a- Cathodic protection using Sacrificial Anode Systems

Sacrificial anodes are buried and attached to UST components for corrosion protection — as illustrated on the right by an anode attached to a tank. Anodes are pieces of metal that are more electrically active than steel, and thus they suffer the destructive effects of corrosion rather than the steel they are attached to.

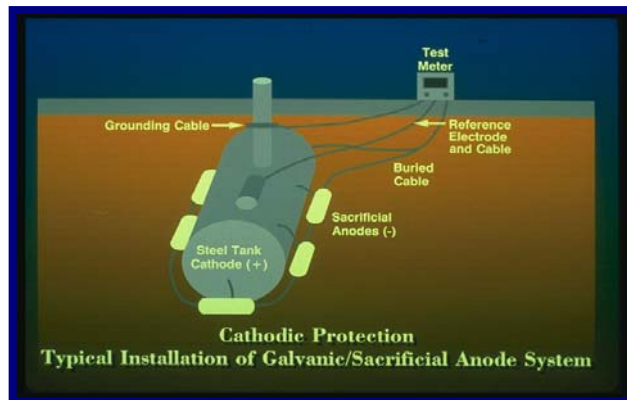

b- Cathodic protection using Impressed Current Systems

An impressed current system — as shown on the right — uses a rectifier to provide direct current through anodes to the tank or piping to achieve corrosion protection. The steel is protected because the current going to the steel overcomes the corrosion-causing current flowing away from it. **The cathodic protection rectifier must always be on and operating to protect your UST system from corrosion.**

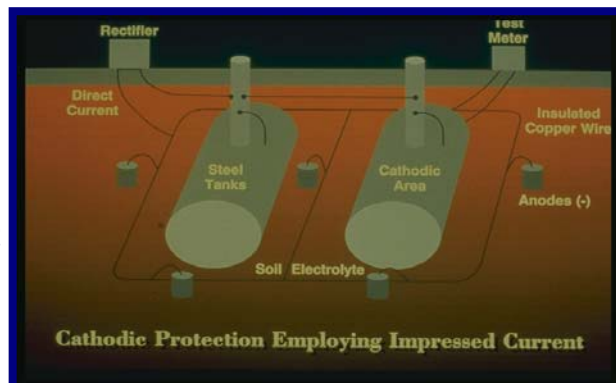

6. Corrosion protection choices

- **Corrosion protection using *Internal Lining* of the tank**

This corrosion protection option applies only to tanks installed before December 22, 1988. These older tanks can be internally lined by trained professionals to meet the corrosion protection requirements — as shown on the right, in which a professional follows industry codes to safely and effectively line a tank’s interior.

It may help you to see your corrosion protection options displayed in the following table.

Corrosion Protection Choices	
Option	Description
Noncorrodible Material	The tank or piping is constructed of noncorrodible material.
Steel Tank Clad Or Jacketed With A Noncorrodible Material	Examples of cladding or jacket material include fiberglass and urethane. Does not apply to piping.
Coated And Cathodically Protected Steel Tanks Or Piping	Steel tank and piping is well-coated with a dielectric material and cathodically protected.
Cathodically Protected Noncoated Steel Tanks Or Piping	<i>This option is only for steel tanks and piping installed before December 22, 1988. Cathodic protection is usually provided by an impressed current system.</i>
Internal Lining Of Tanks	<i>This option is only for steel tanks installed before December 22, 1988. A lining is applied to the inside of the tank. Does not apply to piping.</i>
Combination Of Cathodically Protected Steel And Internal Lining Of Tanks	<i>This option is only for steel tanks installed before December 22, 1988. Cathodic protection is usually provided by an impressed current system. Does not apply to piping.</i>
Other Methods Used To Achieve Corrosion Protection	If you have tanks or piping that do not meet any of the descriptions above, check with DENR to see if your UST system meets the requirements for corrosion protection.

Note: In addition to tanks and piping, all other metal components in direct contact with the ground that routinely hold product — such as flexible connectors, swing joints, fittings, and pumps — must also be cathodically protected.

7. Corrosion protection checklist

Corrosion Protection Checklist	
Sacrificial Anode Cathodic Protection Systems	<p>You need to have a periodic test conducted by a qualified corrosion tester to make sure your cathodic protection system is adequately protecting your UST system. This test needs to be conducted:</p> <ul style="list-style-type: none"> <input type="checkbox"/> Within 6 months of installation. <input type="checkbox"/> At least every 3 years after the previous test. <input type="checkbox"/> Within 6 months after any repairs to your UST system. <ul style="list-style-type: none"> • Make sure the professional tester is qualified to perform the test and follows a standard code of practice to determine that test criteria are adequate. • If any test indicates your tanks are not adequately protected, you need to have a corrosion expert examine and fix your system. • Testing more frequently can catch problems before they become big problems. <input type="checkbox"/> You need to keep the results of at least the last two tests on file.
Impressed Current Cathodic Protection Systems	<p>You need to have a periodic test conducted by a qualified corrosion tester to make sure your cathodic protection system is adequately protecting your UST system. This test needs to be conducted:</p> <ul style="list-style-type: none"> <input type="checkbox"/> Within 6 months of installation. <input type="checkbox"/> At least every 3 years after the previous test. <input type="checkbox"/> Within 6 months after any repairs to your UST system. <ul style="list-style-type: none"> • Make sure the professional tester is qualified to perform the test and follows a standard code of practice to determine that test criteria are adequate. • If any test indicates your tanks are not adequately protected, you need to have a corrosion expert examine and fix your system. • Testing more frequently can catch problems before they become big problems. <input type="checkbox"/> You need to keep the results of at least the last two tests on file. See next page for a cathodic protection test record keeping form. <input type="checkbox"/> You need to inspect your rectifier at least every 60 days to make sure that it is operating within normal limits. <ul style="list-style-type: none"> • This inspection involves reading and recording the voltage and amperage readouts on the rectifier. You or your employees can perform this periodic inspection. • Make sure your cathodic protection professional provides you with the rectifier's acceptable operating levels so you can compare the readings you take with an acceptable operating level. If your readings are not within acceptable levels, you must contact a cathodic protection professional to address the problem. <input type="checkbox"/> You need to keep records of at least the last 3 rectifier readings. <input type="checkbox"/> Never turn off your rectifier!
Internally Lined Tanks	<ul style="list-style-type: none"> <input type="checkbox"/> Within 10 years after lining and at least every 5 years thereafter, the lined tank must be inspected by a trained professional and found to be structurally sound with the lining still performing according to original design specifications. Make sure the professional performing the inspection follows a standard code of practice. <input type="checkbox"/> Keep records of the inspection.

Record for Periodic Testing of Cathodic Protection Systems

Testing must be conducted by a qualified CP tester within six months of installation and at least every three years thereafter and within six months of any repair activity.

I. Facility Information		II. Cathodic Protection (CP) Tester Information	
Name:		Firm Name:	
Address:		Address:	
City:	Phone No:	City:	Phone No:

Indicate the standard used to determine that the CP test criteria are adequate: _____

Cathodic Protection Test Method Used (check one)	
100 mV cathodic polarization test	
-850 mV test (Circle one) Note: All readings taken must meet the -850 mV criteria to pass 1) Polarized Potential ("instant off") 2) Potential with CP Applied , IR Drop considered	
Other Accepted Method (please describe)	

Site Sketch: Provide a rough sketch of the tanks and piping, the location of each CP test, and each voltage value obtained. Voltage readings through concrete or asphalt do not provide accurate readings and are not acceptable. Perform sufficient testing to evaluate the entire UST system.

Is the Cathodic Protection System Working Properly? Yes - No (circle one)

I have sufficient education and experience to be a cathodic protection tester; I am competent to perform the tests indicated above; and that the results on this form are a complete and truthful record of all testing at this location on the date shown.



CP Tester Name: _____ Date: _____

KEEP THIS PAPER ON FILE FOR AT LEAST SIX YEARS

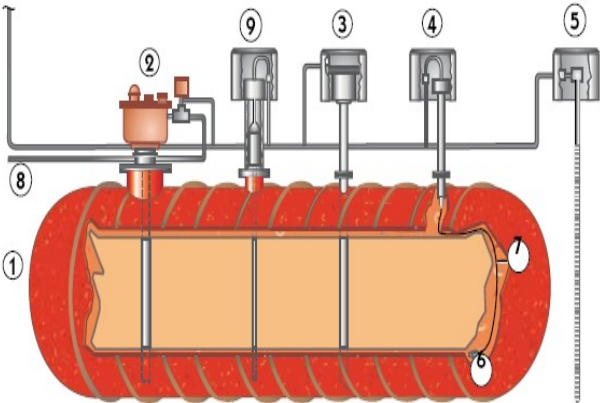
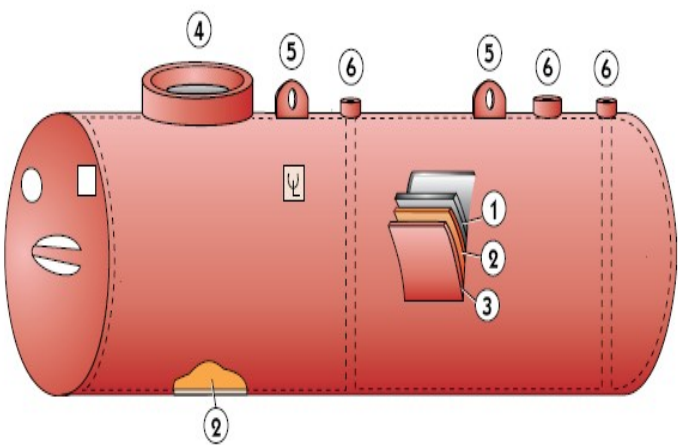
F. Types of Tanks

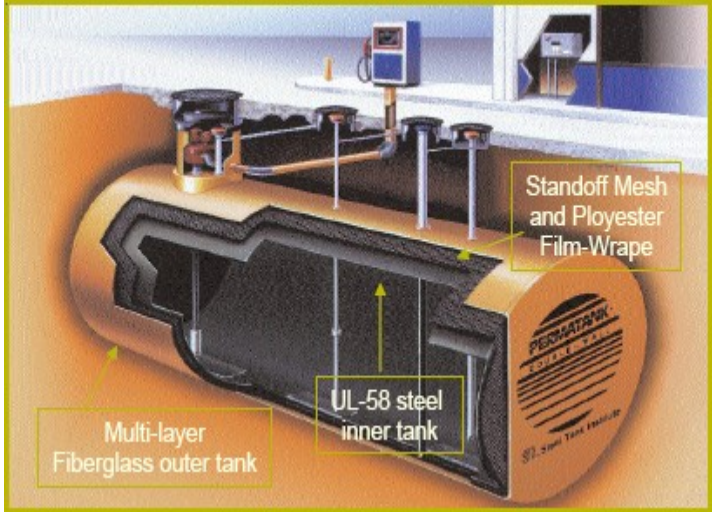
Double Wall Fiberglass Tank	Double Wall Composite Tank
<ul style="list-style-type: none"> 1- Double Wall Fiberglass Tank 2- Sump for Turbine Pump 3- Spill Bucket 4- Sump for Interstitial Monitoring 5- Sump for Monitoring Well (if applicable) 6- Sensor for Leak Detection 7- Wire to Leak Detection Control Panel 8- Fuel Line 9- Sensor for Measuring Fuel 	<ul style="list-style-type: none"> 1- Primary Tank 2- Interstitial Structural Layer 3- Fiberglass Secondary Containment 4- Access for Sump<!--</ul-->
 <p style="text-align: center;">Typical Tank with Components</p>	

ACT-100 Tank	Permatank Tank
<p>ACT-100 composite tanks have their outer surface coated with 100 mils of fiberglass reinforced plastic.</p>	<p>Permatank frp-jacketed tanks have an inner steel tank and an outer tank of multi-layer fiberglass. The built-in interstitial space can be easily checked for leaks.</p>
	

Sti-p3 Single Wall	Sti-p3 Double Walled
<p>Sti-p3 means three methods of protection against external corrosion;</p> <ul style="list-style-type: none"> • Dielectric bushings. • Corrosion resistant coatings. • Sacrificial anodes. 	
	

G. Submersible Turbine Pump and Line leak Detectors

Submersible Turbine Pump for Pressurized Product Lines







Mechanical Line leak Detector



Electronic Line leak Detector



H. Release Response Important Contact Information

Release Response Important Contact Information					
Agency	DENR	PRCF	Fire Department	Police	Spill Cleanup Contractor
Contact	Bob McDonald	Alan Bakeberg			
Phone #	(605) 773-3296 After Hours (605) 773-3231	(605) 773-3769		911	
	Stop the release: Take immediate action to prevent the release of more product. Turn off the power to the dispenser and bag the nozzle. Make sure you know where your emergency shutoff switch is located. Empty the tank, if necessary, without further contaminating the site.				
	Contain the release: Contain, absorb, and clean up any surface releases. Identify any fire, explosion, or vapor hazards and take action to neutralize these hazards.				
	Call for help and to report suspected or confirmed releases: Contact your local fire or emergency response agency. Call DENR within 24-hours.				
	Call National Response Center at 800-424-8802				

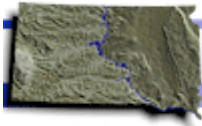

It is the responsibility of the Class A/B Operator to train Class C individuals. Class C operators must be trained to address emergencies presented by a spill or release from an underground storage tank system prior to taking daily responsibility. They must be able to shut-off fuel pumps in case of emergency and able to respond to other warnings and alarms and also be able to contact DENR.

FACILITY INFORMATION

Name: _____
 Address: _____
 City: _____
 County: _____

What does a Class C Operator Need to Know in an Emergency?

- What is a spill or release?
- Where is the shutoff switch or breaker for the dispensers/pumps?
- Who to call?
- Where is the absorbent material? Sandbags? Spill kit?
- What to do about an alarm?

What Does a Class C Operator Need To Do in an Emergency?

- If there is a fire, call 911 first
- Stop the release of product from the UST system
- Contain the release so it doesn't go down a storm drain, in the grass or off the property
- Call the main office or supervisor
- Call DENR ... (605) 773-3296. After Hours... (605) 773-3231

CERTIFICATION:

Class C Operator

By my signature below, I certify that I have received training in the areas mentioned above.

Print Name: _____
 Signature: _____
 Date: _____

Class A/B Operator

By my signature below, I certify that I have trained the employee named in this form.

Print Name: _____
 Signature: _____
 Date: _____

J. Notification Forms

Notification for Underground Storage Tanks

Ground Water Quality Program, Storage Tank Section 523 East Capitol, Pierre, SD 57501 Phone # (605) 773-3296, Fax # (605) 773-6035 www.state.sd.us/DENR			STATE USE ONLY		
			FACILITY ID NUMBER: _____		
			DENR P&S NUMBER: _____		
TYPE OF NOTIFICATION			DATE RECEIVED: _____		
<input type="checkbox"/> A. NEW	<input type="checkbox"/> B. AMENDED	<input type="checkbox"/> C. CLOSURE	A. Date Entered into Compute _____		
No. of tanks _____ at facility			B. Data Entry Clerk Initials _____		
		No. of continuation sheets attached _____	C. Owner was contacted to clarify responses, comments: _____ _____ _____		
INSTRUCTIONS					
Please <u>type or print in ink</u> all items. This form must be completed for each location containing underground storage tanks. If more than five (5) tanks are owned at this location, photocopy the following sheets, and staple continuation sheets to the form.					

GENERAL INFORMATION

Notification is required by Federal law for all underground tanks that have been used to store regulated substances since January 1, 1974, that are in the ground as of May 8, 1986, or that are brought into use after May 8, 1986. The information requested is required by Section 9002 of the Resource Conservation and Recovery Act (RCRA), as amended.

The primary purpose of this notification program is to locate and evaluate underground tanks that store or have stored petroleum or hazardous substances. It is expected that the information you provide will be based on reasonably available records, or in the absence of such records, your knowledge, belief, or recollection.

Who Must Notify? Section 9002 of RCRA, as amended, requires that, unless exempted, owners of underground tanks that store regulated substances must notify designated State or local agencies of the existence of their tanks. Owner means--

- (a) in the case of an underground storage tank in use on November 8, 1984, or brought into use after that date, any person who owns an underground storage tank used for storage, use, or dispensing of regulated substances, and
- (b) in the case of any underground storage tank in use before November 8, 1984, but no longer in use on that date, any person who owned such tank immediately before discontinuation of its use.

What Tanks Are Included? Underground storage tank is defined as any one or combination of tanks that (1) is used to contain an accumulation of "regulated substances," and (2) whose volume (including connected underground piping) is 10% or more beneath the ground. Some examples are underground tanks storing: 1. gasoline, used oil or diesel fuel, and 2. industrial solvents, pesticides, herbicides or fumigants.

What Tanks Are Excluded? Tanks removed from the ground are not subject to notification. Other tanks excluded from notification are:

- 1. farm or residential tanks of 1100 gallons or less capacity used for storing motor fuel for noncommercial purposes;
- 2. tanks used for storing heating oil for consumptive use on the premises where stored;
- 3. septic tanks;

- 4. pipeline facilities (including gathering lines) regulated under the Natural Gas Pipeline Safety Act of 1968, or the Hazardous Liquid Pipeline Safety Act of 1979, or which is an intrastate pipeline facility regulated under State laws;
- 5. surface impoundments, pits, ponds, or lagoons;
- 6. storm water or waste water collection systems;
- 7. flow-through process tanks;
- 8. liquid traps or associated gathering lines directly related to oil or gas production and gathering operations;
- 9. storage tanks situated in an underground area (such as a basement, cellar, mineworking, drift, shaft, or tunnel) if the storage tank is situated upon or above the surface floor;
- 10. Pipes connected to any tank which is exempt;
- 11. Tanks used for storing pesticides regulated under chapter 38-21, except those regulated pursuant to subtitle I of the Federal Hazardous and Solid Waste amendments of 1984.

What Substances Are Covered? This includes any substance defined as hazardous in Section 101 (14) of the Comprehensive Environmental Response, Compensation and Liability Act of 1980 (CERCLA), with the exception of those substances regulated as hazardous waste under Subtitle C of RCRA. It also includes petroleum, e.g., crude oil or any fraction thereof which is liquid at standard conditions of temperature and pressure (60 degrees Fahrenheit and 14.7 pounds per square inch absolute).

Where To Notify? Send completed forms to:

Ground Water Quality Program, Storage Tank Section
523 East Capitol, Pierre, SD 57501
Phone # (605) 773-3296

When To Notify? 1. Owners of underground storage tanks in use or that have been taken out of operation after January 1, 1974, but still in the ground, must notify by May 8, 1986. 2. Owners who bring underground storage tanks into use after May 8, 1986, must notify within 30 days of bringing the tanks into use.

Penalties: Any owner who knowingly fails to notify or submits false information shall be subject to a civil penalty not to exceed \$10,000 for each tank for which notification is not given or for which false information is submitted.

I. OWNERSHIP OF TANK(S)			II. LOCATION OF TANK(S)		
Owner Name (Corporation, Individual, Public Agency, or Other Entity)			If known, give the geographic location of tanks by degrees, minutes, and seconds. Examples Lat. 42, 36, 12 N Long. 85, 24, 17 W Latitude _____ Longitude _____		
Street Address			Facility Name or Company Site Identifier, as applicable		(if same as Section I, mark box here) <input type="checkbox"/>
City			Street Address		
State	City	Zip Code			
County	City	State	Zip Code		
Phone Number (include Area Code)			County		Phone Number (include Area Code)

Notification for Underground Storage Tanks

III. TYPE OF OWNER

- | | |
|---|-------------------------------------|
| <input type="checkbox"/> Federal Government | <input type="checkbox"/> Commercial |
| <input type="checkbox"/> State Government | <input type="checkbox"/> Private |
| <input type="checkbox"/> Local Government | |

IV. INDIAN LANDS

Tanks are located on land within an Indian Reservation or on other trust lands.
 Tanks are owned by native American nation, tribe, or individual

Tribe or Nation:

V. TYPE OF FACILITY

- | | | |
|--|---|---|
| <input type="checkbox"/> Gas Station | <input type="checkbox"/> Railroad | <input type="checkbox"/> Trucking/Transport |
| <input type="checkbox"/> Petroleum Distributor | <input type="checkbox"/> Federal - Non-Military | <input type="checkbox"/> Utilities |
| <input type="checkbox"/> Air Taxi (Airline) | <input type="checkbox"/> Federal - Military | <input type="checkbox"/> Residential |
| <input type="checkbox"/> Aircraft /Airport Owner | <input type="checkbox"/> Industrial | <input type="checkbox"/> Farm |
| <input type="checkbox"/> Auto Dealership/Repair Shop | <input type="checkbox"/> Contractor | <input type="checkbox"/> Other (Explain) |

VI. CONTACT PERSON IN CHARGE OF TANKS

Name:	Job Title:	Address:	Phone Number (Include Area Code):
-------	------------	----------	-----------------------------------

VII. FINANCIAL RESPONSIBILITY

I have met the financial responsibility requirements
 in accordance with 40 CFR Subpart H

Check All that Apply

- | | | |
|---|---|---|
| <input type="checkbox"/> Self Insurance | <input type="checkbox"/> Guarantee | <input type="checkbox"/> State Funds |
| <input type="checkbox"/> Commercial Insurance | <input type="checkbox"/> Surety Bond | <input type="checkbox"/> Trust Fund |
| <input type="checkbox"/> Risk Retention Group | <input type="checkbox"/> Letter of Credit | <input type="checkbox"/> Other Method Allowed - Specify |

VIII. CERTIFICATION

I certify under penalty of law that I have personally examined and am familiar with the information submitted in this and all attached documents, and that based on my inquiry of those individuals immediately responsible for obtaining the information, I believe that the submitted information is true, accurate, and complete.

Name and official title of owner or owner's
 authorized representative (Print)

Notification for Underground Storage Tanks

IX. DESCRIPTION OF UNDERGROUND STORAGE TANKS (Complete for each tank at this location.)

Tank Identification Number	Tank No.	Tank No.	Tank No.	Tank No.	Tank No.
1. Status of Tank (mark only one)					
Currently In Use	<input type="checkbox"/>	<input type="checkbox"/>	<input type="checkbox"/>	<input type="checkbox"/>	<input type="checkbox"/>
Temporarily Out of Use	<input type="checkbox"/>	<input type="checkbox"/>	<input type="checkbox"/>	<input type="checkbox"/>	<input type="checkbox"/>
Permanently Out of Use	<input type="checkbox"/>	<input type="checkbox"/>	<input type="checkbox"/>	<input type="checkbox"/>	<input type="checkbox"/>
2. Date of Installation (mo./year)					
3. Estimated Total Capacity (gallons)					
4. Material of Construction (mark all that apply)					
Asphalt Coated or Bare Steel	<input type="checkbox"/>	<input type="checkbox"/>	<input type="checkbox"/>	<input type="checkbox"/>	<input type="checkbox"/>
Manufactured Cathodically Protected Steel (sti-P ₃ Tank)	<input type="checkbox"/>	<input type="checkbox"/>	<input type="checkbox"/>	<input type="checkbox"/>	<input type="checkbox"/>
Field Installed Impressed Current	<input type="checkbox"/>	<input type="checkbox"/>	<input type="checkbox"/>	<input type="checkbox"/>	<input type="checkbox"/>
Epoxy Coated Steel	<input type="checkbox"/>	<input type="checkbox"/>	<input type="checkbox"/>	<input type="checkbox"/>	<input type="checkbox"/>
Composite (Steel with Fiberglass)	<input type="checkbox"/>	<input type="checkbox"/>	<input type="checkbox"/>	<input type="checkbox"/>	<input type="checkbox"/>
Fiberglass Reinforced Plastic	<input type="checkbox"/>	<input type="checkbox"/>	<input type="checkbox"/>	<input type="checkbox"/>	<input type="checkbox"/>
Lined Interior	<input type="checkbox"/>	<input type="checkbox"/>	<input type="checkbox"/>	<input type="checkbox"/>	<input type="checkbox"/>
Double Walled	<input type="checkbox"/>	<input type="checkbox"/>	<input type="checkbox"/>	<input type="checkbox"/>	<input type="checkbox"/>
Polyethylene Tank Jacket	<input type="checkbox"/>	<input type="checkbox"/>	<input type="checkbox"/>	<input type="checkbox"/>	<input type="checkbox"/>
Concrete	<input type="checkbox"/>	<input type="checkbox"/>	<input type="checkbox"/>	<input type="checkbox"/>	<input type="checkbox"/>
Excavation Liner	<input type="checkbox"/>	<input type="checkbox"/>	<input type="checkbox"/>	<input type="checkbox"/>	<input type="checkbox"/>
Unknown	<input type="checkbox"/>	<input type="checkbox"/>	<input type="checkbox"/>	<input type="checkbox"/>	<input type="checkbox"/>
Other, Please specify	_____	_____	_____	_____	_____
Has tank been repaired?	<input type="checkbox"/>	<input type="checkbox"/>	<input type="checkbox"/>	<input type="checkbox"/>	<input type="checkbox"/>
5. Piping (Material) (mark all that apply)					
Bare Steel	<input type="checkbox"/>	<input type="checkbox"/>	<input type="checkbox"/>	<input type="checkbox"/>	<input type="checkbox"/>
Galvanized Steel	<input type="checkbox"/>	<input type="checkbox"/>	<input type="checkbox"/>	<input type="checkbox"/>	<input type="checkbox"/>
Fiberglass Reinforced Plastic	<input type="checkbox"/>	<input type="checkbox"/>	<input type="checkbox"/>	<input type="checkbox"/>	<input type="checkbox"/>
Copper	<input type="checkbox"/>	<input type="checkbox"/>	<input type="checkbox"/>	<input type="checkbox"/>	<input type="checkbox"/>
Cathodically Protected	<input type="checkbox"/>	<input type="checkbox"/>	<input type="checkbox"/>	<input type="checkbox"/>	<input type="checkbox"/>
Double Walled	<input type="checkbox"/>	<input type="checkbox"/>	<input type="checkbox"/>	<input type="checkbox"/>	<input type="checkbox"/>
Secondary Containment	<input type="checkbox"/>	<input type="checkbox"/>	<input type="checkbox"/>	<input type="checkbox"/>	<input type="checkbox"/>
Unknown	<input type="checkbox"/>	<input type="checkbox"/>	<input type="checkbox"/>	<input type="checkbox"/>	<input type="checkbox"/>
Other, Please Specify	_____	_____	_____	_____	_____
6. Piping (Type) (mark all that apply)					
Suction: no valve at tank	<input type="checkbox"/>	<input type="checkbox"/>	<input type="checkbox"/>	<input type="checkbox"/>	<input type="checkbox"/>
Suction: valve at tank	<input type="checkbox"/>	<input type="checkbox"/>	<input type="checkbox"/>	<input type="checkbox"/>	<input type="checkbox"/>
Pressure	<input type="checkbox"/>	<input type="checkbox"/>	<input type="checkbox"/>	<input type="checkbox"/>	<input type="checkbox"/>
Gravity Feed	<input type="checkbox"/>	<input type="checkbox"/>	<input type="checkbox"/>	<input type="checkbox"/>	<input type="checkbox"/>
Has piping been repaired?	<input type="checkbox"/>	<input type="checkbox"/>	<input type="checkbox"/>	<input type="checkbox"/>	<input type="checkbox"/>

Notification for Underground Storage Tanks

Tank Identification Number	Tank No.	Tank No.	Tank No.	Tank No.	Tank No.
7. Substance Currently or Last Stored in Greatest Quantity by Volume					
Gasoline	<input type="checkbox"/>	<input type="checkbox"/>	<input type="checkbox"/>	<input type="checkbox"/>	<input type="checkbox"/>
Diesel	<input type="checkbox"/>	<input type="checkbox"/>	<input type="checkbox"/>	<input type="checkbox"/>	<input type="checkbox"/>
Gasohol	<input type="checkbox"/>	<input type="checkbox"/>	<input type="checkbox"/>	<input type="checkbox"/>	<input type="checkbox"/>
Kerosene	<input type="checkbox"/>	<input type="checkbox"/>	<input type="checkbox"/>	<input type="checkbox"/>	<input type="checkbox"/>
Heating Oil	<input type="checkbox"/>	<input type="checkbox"/>	<input type="checkbox"/>	<input type="checkbox"/>	<input type="checkbox"/>
Used Oil	<input type="checkbox"/>	<input type="checkbox"/>	<input type="checkbox"/>	<input type="checkbox"/>	<input type="checkbox"/>
Aviation Fuel	<input type="checkbox"/>	<input type="checkbox"/>	<input type="checkbox"/>	<input type="checkbox"/>	<input type="checkbox"/>
Jet Fuel	<input type="checkbox"/>	<input type="checkbox"/>	<input type="checkbox"/>	<input type="checkbox"/>	<input type="checkbox"/>
E85	<input type="checkbox"/>	<input type="checkbox"/>	<input type="checkbox"/>	<input type="checkbox"/>	<input type="checkbox"/>
Other	<input type="checkbox"/>	<input type="checkbox"/>	<input type="checkbox"/>	<input type="checkbox"/>	<input type="checkbox"/>
Please Specify	_____	_____	_____	_____	_____
Hazardous Substance	<input type="checkbox"/>	<input type="checkbox"/>	<input type="checkbox"/>	<input type="checkbox"/>	<input type="checkbox"/>
CERCLA name and/or CAS number	_____ _____	_____ _____	_____ _____	_____ _____	_____ _____
Mixture of Substances	<input type="checkbox"/>	<input type="checkbox"/>	<input type="checkbox"/>	<input type="checkbox"/>	<input type="checkbox"/>
Please Specify	_____	_____	_____	_____	_____

X. TANKS OUT OF USE, OR CHANGE IN SERVICE

1. Closing of Tank					
A. Estimated date last used (mo./day/year)					
B. Estimated date tank closed (mo./day/year)					
C. Tank was removed from ground	<input type="checkbox"/>	<input type="checkbox"/>	<input type="checkbox"/>	<input type="checkbox"/>	<input type="checkbox"/>
D. Tank was closed in ground	<input type="checkbox"/>	<input type="checkbox"/>	<input type="checkbox"/>	<input type="checkbox"/>	<input type="checkbox"/>
E. Tank filled with inert material	<input type="checkbox"/>	<input type="checkbox"/>	<input type="checkbox"/>	<input type="checkbox"/>	<input type="checkbox"/>
Describe	_____ _____ _____	_____ _____ _____	_____ _____ _____	_____ _____ _____	_____ _____ _____
F. Change in service	<input type="checkbox"/>	<input type="checkbox"/>	<input type="checkbox"/>	<input type="checkbox"/>	<input type="checkbox"/>
2. Site Assessment Completed (DENR Spill Number, if known)	<input type="checkbox"/>	<input type="checkbox"/>	<input type="checkbox"/>	<input type="checkbox"/>	<input type="checkbox"/>
3. Evidence of a leak detected	<input type="checkbox"/>	<input type="checkbox"/>	<input type="checkbox"/>	<input type="checkbox"/>	<input type="checkbox"/>

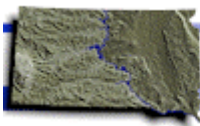

Notification for Aboveground Stationary Storage Tanks

Ground Water Quality Program, Storage Tank Section 523 East Capitol, Pierre, SD 57501 Phone # (605) 773-3296, Fax # (605) 773-6035 www.state.sd.us/DENR		STATE USE ONLY	
		FACILITY ID NUMBER:	
		DATE RECEIVED:	
TYPE OF NOTIFICATION			
<input type="checkbox"/> A. NEW	<input type="checkbox"/> B. AMENDED	<input type="checkbox"/> C. CLOSURE	
No. of tanks _____ at facility	No. of continuation sheets attached _____		
INSTRUCTIONS			
Please <u>type or print in ink</u> all items except "signature" in section VIII. This form must be completed for each location containing aboveground storage tanks. If more than five (5) tanks are owned at this location, photocopy the following sheets, and staple continuation sheets to the form.			
		A. Date Entered into Computer _____ B. Data Entry Clerk Initials _____ C. Owner Was Contacted to Clarify Responses, Comments: _____ _____ _____ _____	

GENERAL INFORMATION

Notification is required by State law for all aboveground stationary tanks that have been used to store regulated substances since January 1, 1974, that are in the ground as of May 9, 1988, or that are brought into use after May 9, 1988. The information requested is required by Chapter 74:56:03 of the Administrative Rules of South Dakota.

The primary purpose of this notification program is to locate and evaluate aboveground stationary tanks that store or have stored petroleum or hazardous substances. It is expected that the information you provide will be based on reasonably available records, or in the absence of such records, your knowledge, belief, or recollection.

Who Must Notify? Chapter 74:56:03 of the Administrative Rules of South Dakota requires that, unless exempted, owners of aboveground stationary tanks that store regulated substances must notify designated State or local agencies of the existence of their tanks. Owner means--

(a) **in the case of an aboveground stationary storage tank in use on November 30, 1987, or brought into use after that date, any person who owns an aboveground stationary storage tank used for storage, use, or dispensing of regulated substances, and**

(b) **in the case of any aboveground stationary storage tank in use before November 30, 1987, but no longer in use on that date, any person who owned such tank immediately before discontinuation of its use.**

What Tanks Are Included? Aboveground stationary storage tank is defined as "Aboveground storage tank, which do not move, such as tanks fixed permanently in place on foundations, racks, cradles or stilts, or on the ground. The term does not include tanks mounted on wheels, trolleys, skids, pallets, or rollers and vessels such as a 55-gallon drum or smaller vessels or produced substance storage tanks directly related to oil and gas production and gathering operations or tanks located within a building structure meeting requirements in Chapter 74:56:03: 11. An aboveground storage tank system is defined as "an aboveground stationary storage tank or combination of tanks, including connected piping".

What Tanks Are Excluded? Tanks excluded from notification are:

- farm or residential tanks used for storing motor fuel for noncommercial purposes;
- tanks used for storing heating oil or motor fuels for consumptive use on the premises where stored;
- septic tanks;
- pipeline facilities (including gathering lines) regulated under the Natural Gas Pipeline Safety Act of 1968, or the Hazardous Liquid Pipeline Safety Act of 1979, or which is an intrastate pipeline facility regulated under State laws;
- surface impoundments, pits, ponds, or lagoons;
- storm water or waste water collection systems;
- flow-through process tanks;
- liquid traps or associated gathering lines directly related to oil or gas production and gathering operations;
- storage tanks situated in an underground area (such as a basement, cellar, mineworking, drift, shaft, or tunnel) if the storage tank is situated upon or above the surface floor;
- Pipes connected to any tank which is exempt;
- Tanks used for storing pesticides regulated under chapter 38-21, except those regulated pursuant to subtitle I of the Federal Hazardous and Solid Waste amendments of 1984.

What Substances Are Covered? This includes any substance defined as hazardous in Section 101 (14) of the Comprehensive Environmental Response, Compensation and Liability Act of 1980 (CERCLA), with the exception of those substances regulated as hazardous waste under Subtitle C of RCRA. It also includes petroleum, e.g., crude oil or any fraction thereof which is liquid at standard conditions of temperature and pressure (60 degrees Fahrenheit and 14.7 pounds per square inch absolute).

Where To Notify? Send completed forms to:

Ground Water Quality Program, Storage Tank Section
 523 East Capitol, Pierre, SD 57501
 Phone # (605) 773-3296

When To Notify? 1. Owners of aboveground stationary storage tanks in use or that have been taken out of operation after January 1, 1974, but still in the ground, must notify by May 9, 1988. 2. Owners who bring aboveground stationary storage tanks into use after May 9, 1988, must notify within 30 days of bringing the tanks into use.

Penalties: Any owner who knowingly fails to notify or submits false information shall be subject to a civil penalty not to exceed \$10,000 for each tank for which notification is not given or for which false information is submitted.

I. OWNERSHIP OF TANK(S)			II. LOCATION OF TANK(S)		
Owner Name (Corporation, Individual, Public Agency, or Other Entity)			If known, give the geographic location of tanks by degrees, minutes, and seconds. Examples Lat. 42, 36, 12 N Long. 85, 24, 17 W		
Street Address			Latitude _____ Longitude _____		(if same as Section I, mark box here) <input type="checkbox"/>
Street Address			Facility Name of Company Site Identifier, as applicable		
City			Street Address		
State			City		
Zip Code			State		
County			Zip Code		
Phone Number (include Area Code)			County		Phone Number (include Area Code)

South Dakota
Department of Environment and Natural Resources
 Pierre, SD 57501

DENR ID NUMBER
 (STATE USE ONLY)

Notification for Aboveground Stationary Storage Tanks

III. TYPE OF OWNER

- | | |
|---|-------------------------------------|
| <input type="checkbox"/> Federal Government | <input type="checkbox"/> Commercial |
| <input type="checkbox"/> State Government | <input type="checkbox"/> Private |
| <input type="checkbox"/> Local Government | |

IV. INDIAN LANDS

Tanks are located on land within an Indian Reservation or on other trust lands.
 Tanks are owned by native American nation, tribe, or individual

Tribe or Nation:

V. TYPE OF FACILITY

- | | | |
|--|---|---|
| <input type="checkbox"/> Gas Station | <input type="checkbox"/> Railroad | <input type="checkbox"/> Trucking/Transport |
| <input type="checkbox"/> Petroleum Distributor | <input type="checkbox"/> Federal - Non-Military | <input type="checkbox"/> Utilities |
| <input type="checkbox"/> Air Taxi (Airline) | <input type="checkbox"/> Federal - Military | <input type="checkbox"/> Residential |
| <input type="checkbox"/> Aircraft /Airport Owner | <input type="checkbox"/> Industrial | <input type="checkbox"/> Farm |
| <input type="checkbox"/> Auto Dealership/Repair Shop | <input type="checkbox"/> Contractor | <input type="checkbox"/> Other (Explain)
_____ |

VI. CONTACT PERSON IN CHARGE OF TANKS

Name:	Job Title:	Address:	Phone Number (Include Area Code):
-------	------------	----------	-----------------------------------

VII. FINANCIAL RESPONSIBILITY

Check All that Apply

- | | | |
|---|---|--|
| <input type="checkbox"/> Self Insurance | <input type="checkbox"/> Guarantee | <input type="checkbox"/> State Funds |
| <input type="checkbox"/> Commercial Insurance | <input type="checkbox"/> Surety Bond | <input type="checkbox"/> Trust Fund |
| <input type="checkbox"/> Risk Retention Group | <input type="checkbox"/> Letter of Credit | <input type="checkbox"/> Other Method Allowed - Specify
_____ |

VIII. CERTIFICATION (Read and sign after completing all section)

I certify under penalty of law that I have personally examined and am familiar with the information submitted in this and all attached documents, and that based on my inquiry of those individuals immediately responsible for obtaining the information, I believe that the submitted information is true, accurate, and complete.

Name and official title of owner or owner's authorized representative (Print)	Signature	Date Signed
---	-----------	-------------

Notification for Aboveground Stationary Storage Tanks

IX. DESCRIPTION OF ABOVEGROUND STORAGE TANKS (Complete for each tank at this location.)

Tank Identification Number	Tank No.	Tank No.	Tank No.	Tank No.	Tank No.
1. Status of Tank (mark only one)					
Currently In Use	<input type="checkbox"/>	<input type="checkbox"/>	<input type="checkbox"/>	<input type="checkbox"/>	<input type="checkbox"/>
Temporarily Out of Use	<input type="checkbox"/>	<input type="checkbox"/>	<input type="checkbox"/>	<input type="checkbox"/>	<input type="checkbox"/>
Permanently Out of Use	<input type="checkbox"/>	<input type="checkbox"/>	<input type="checkbox"/>	<input type="checkbox"/>	<input type="checkbox"/>
2. Date of Installation (mo./year)					
3. Estimated Total Capacity (gallons)	_____	_____	_____	_____	_____
4. Material of Construction (mark all that apply)					
Bare Steel	<input type="checkbox"/>	<input type="checkbox"/>	<input type="checkbox"/>	<input type="checkbox"/>	<input type="checkbox"/>
Manufactured Cathodically Protected Steel	<input type="checkbox"/>	<input type="checkbox"/>	<input type="checkbox"/>	<input type="checkbox"/>	<input type="checkbox"/>
Field Installed Impressed Current	<input type="checkbox"/>	<input type="checkbox"/>	<input type="checkbox"/>	<input type="checkbox"/>	<input type="checkbox"/>
Coated Steel	<input type="checkbox"/>	<input type="checkbox"/>	<input type="checkbox"/>	<input type="checkbox"/>	<input type="checkbox"/>
Double Walled	<input type="checkbox"/>	<input type="checkbox"/>	<input type="checkbox"/>	<input type="checkbox"/>	<input type="checkbox"/>
Lined Interior	<input type="checkbox"/>	<input type="checkbox"/>	<input type="checkbox"/>	<input type="checkbox"/>	<input type="checkbox"/>
horizontal	<input type="checkbox"/>	<input type="checkbox"/>	<input type="checkbox"/>	<input type="checkbox"/>	<input type="checkbox"/>
vertical	<input type="checkbox"/>	<input type="checkbox"/>	<input type="checkbox"/>	<input type="checkbox"/>	<input type="checkbox"/>
Concrete	<input type="checkbox"/>	<input type="checkbox"/>	<input type="checkbox"/>	<input type="checkbox"/>	<input type="checkbox"/>
Excavation Liner	<input type="checkbox"/>	<input type="checkbox"/>	<input type="checkbox"/>	<input type="checkbox"/>	<input type="checkbox"/>
Unknown	<input type="checkbox"/>	<input type="checkbox"/>	<input type="checkbox"/>	<input type="checkbox"/>	<input type="checkbox"/>
Other, Please specify	_____	_____	_____	_____	_____
Has tank been repaired?	<input type="checkbox"/>	<input type="checkbox"/>	<input type="checkbox"/>	<input type="checkbox"/>	<input type="checkbox"/>
5. Piping (Material) (mark all that apply)					
Bare Steel	<input type="checkbox"/>	<input type="checkbox"/>	<input type="checkbox"/>	<input type="checkbox"/>	<input type="checkbox"/>
Galvanized Steel	<input type="checkbox"/>	<input type="checkbox"/>	<input type="checkbox"/>	<input type="checkbox"/>	<input type="checkbox"/>
Fiberglass Reinforced Plastic	<input type="checkbox"/>	<input type="checkbox"/>	<input type="checkbox"/>	<input type="checkbox"/>	<input type="checkbox"/>
Copper	<input type="checkbox"/>	<input type="checkbox"/>	<input type="checkbox"/>	<input type="checkbox"/>	<input type="checkbox"/>
Cathodically Protected	<input type="checkbox"/>	<input type="checkbox"/>	<input type="checkbox"/>	<input type="checkbox"/>	<input type="checkbox"/>
Double Walled	<input type="checkbox"/>	<input type="checkbox"/>	<input type="checkbox"/>	<input type="checkbox"/>	<input type="checkbox"/>
Secondary Containment	<input type="checkbox"/>	<input type="checkbox"/>	<input type="checkbox"/>	<input type="checkbox"/>	<input type="checkbox"/>
Unknown	<input type="checkbox"/>	<input type="checkbox"/>	<input type="checkbox"/>	<input type="checkbox"/>	<input type="checkbox"/>
Other, Please Specify	_____	_____	_____	_____	_____
6. Piping (Type) (mark all that apply)					
underground piping	<input type="checkbox"/>	<input type="checkbox"/>	<input type="checkbox"/>	<input type="checkbox"/>	<input type="checkbox"/>
aboveground piping	<input type="checkbox"/>	<input type="checkbox"/>	<input type="checkbox"/>	<input type="checkbox"/>	<input type="checkbox"/>
Pressure	<input type="checkbox"/>	<input type="checkbox"/>	<input type="checkbox"/>	<input type="checkbox"/>	<input type="checkbox"/>
Gravity Feed	<input type="checkbox"/>	<input type="checkbox"/>	<input type="checkbox"/>	<input type="checkbox"/>	<input type="checkbox"/>
Has piping been repaired?	<input type="checkbox"/>	<input type="checkbox"/>	<input type="checkbox"/>	<input type="checkbox"/>	<input type="checkbox"/>

Notification for Aboveground Stationary Storage Tanks

Tank Identification Number	Tank No.	Tank No.	Tank No.	Tank No.	Tank No.
7. Substance Currently or Last Stored in Greatest Quantity by Volume					
Gasoline	<input type="checkbox"/>	<input type="checkbox"/>	<input type="checkbox"/>	<input type="checkbox"/>	<input type="checkbox"/>
Diesel	<input type="checkbox"/>	<input type="checkbox"/>	<input type="checkbox"/>	<input type="checkbox"/>	<input type="checkbox"/>
Gasohol	<input type="checkbox"/>	<input type="checkbox"/>	<input type="checkbox"/>	<input type="checkbox"/>	<input type="checkbox"/>
Kerosene	<input type="checkbox"/>	<input type="checkbox"/>	<input type="checkbox"/>	<input type="checkbox"/>	<input type="checkbox"/>
Heating Oil	<input type="checkbox"/>	<input type="checkbox"/>	<input type="checkbox"/>	<input type="checkbox"/>	<input type="checkbox"/>
Used Oil	<input type="checkbox"/>	<input type="checkbox"/>	<input type="checkbox"/>	<input type="checkbox"/>	<input type="checkbox"/>
Aviation Fuel	<input type="checkbox"/>	<input type="checkbox"/>	<input type="checkbox"/>	<input type="checkbox"/>	<input type="checkbox"/>
Jet Fuel	<input type="checkbox"/>	<input type="checkbox"/>	<input type="checkbox"/>	<input type="checkbox"/>	<input type="checkbox"/>
E85	<input type="checkbox"/>	<input type="checkbox"/>	<input type="checkbox"/>	<input type="checkbox"/>	<input type="checkbox"/>
Other	<input type="checkbox"/>	<input type="checkbox"/>	<input type="checkbox"/>	<input type="checkbox"/>	<input type="checkbox"/>
Please Specify	_____	_____	_____	_____	_____
	_____	_____	_____	_____	_____
Hazardous Substance	<input type="checkbox"/>	<input type="checkbox"/>	<input type="checkbox"/>	<input type="checkbox"/>	<input type="checkbox"/>
CERCLA name and/or	_____	_____	_____	_____	_____
CAS number	_____	_____	_____	_____	_____
Mixture of Substances	<input type="checkbox"/>	<input type="checkbox"/>	<input type="checkbox"/>	<input type="checkbox"/>	<input type="checkbox"/>
Please Specify	_____	_____	_____	_____	_____
	_____	_____	_____	_____	_____

X. TANKS OUT OF USE, OR CHANGE IN SERVICE

1. Closing of Tank					
A. Estimated date last used (mo./day/year)					
B. Estimated date tank closed (mo./day/year)					
C. Tank was removed from ground	<input type="checkbox"/>	<input type="checkbox"/>	<input type="checkbox"/>	<input type="checkbox"/>	<input type="checkbox"/>
D. Tank was abandoned in place	<input type="checkbox"/>	<input type="checkbox"/>	<input type="checkbox"/>	<input type="checkbox"/>	<input type="checkbox"/>
E. Other, please describe	<input type="checkbox"/>	<input type="checkbox"/>	<input type="checkbox"/>	<input type="checkbox"/>	<input type="checkbox"/>
	_____	_____	_____	_____	_____
	_____	_____	_____	_____	_____
	_____	_____	_____	_____	_____
	_____	_____	_____	_____	_____
F. Change in service	<input type="checkbox"/>	<input type="checkbox"/>	<input type="checkbox"/>	<input type="checkbox"/>	<input type="checkbox"/>
2. Site Assessment Completed (DENR Spill Number, if known)	<input type="checkbox"/>	<input type="checkbox"/>	<input type="checkbox"/>	<input type="checkbox"/>	<input type="checkbox"/>
Evidence of a leak detected	<input type="checkbox"/>	<input type="checkbox"/>	<input type="checkbox"/>	<input type="checkbox"/>	<input type="checkbox"/>

Notification for Aboveground Stationary Storage Tanks

XI. CERTIFICATION OF COMPLIANCE (COMPLETE FOR ALL NEW AND UPGRADED TANKS AT THIS LOCATION)

Tank Identification Number	Tank No.		Tank No.		Tank No.		Tank No.		Tank No.	
1. Installation										
A. Installer certified by tank and piping manufacturers	<input type="checkbox"/>	<input type="checkbox"/>	<input type="checkbox"/>	<input type="checkbox"/>	<input type="checkbox"/>	<input type="checkbox"/>	<input type="checkbox"/>	<input type="checkbox"/>	<input type="checkbox"/>	<input type="checkbox"/>
B. Installer certified or licensed by DENR	<input type="checkbox"/>	<input type="checkbox"/>	<input type="checkbox"/>	<input type="checkbox"/>	<input type="checkbox"/>	<input type="checkbox"/>	<input type="checkbox"/>	<input type="checkbox"/>	<input type="checkbox"/>	<input type="checkbox"/>
C. Installation inspected by a registered engineer	<input type="checkbox"/>	<input type="checkbox"/>	<input type="checkbox"/>	<input type="checkbox"/>	<input type="checkbox"/>	<input type="checkbox"/>	<input type="checkbox"/>	<input type="checkbox"/>	<input type="checkbox"/>	<input type="checkbox"/>
D. Installation inspected by DENR	<input type="checkbox"/>	<input type="checkbox"/>	<input type="checkbox"/>	<input type="checkbox"/>	<input type="checkbox"/>	<input type="checkbox"/>	<input type="checkbox"/>	<input type="checkbox"/>	<input type="checkbox"/>	<input type="checkbox"/>
E. Plan & Specification approved by DENR	<input type="checkbox"/>	<input type="checkbox"/>	<input type="checkbox"/>	<input type="checkbox"/>	<input type="checkbox"/>	<input type="checkbox"/>	<input type="checkbox"/>	<input type="checkbox"/>	<input type="checkbox"/>	<input type="checkbox"/>
F. Manufacturer's installation checklists have been completed	<input type="checkbox"/>	<input type="checkbox"/>	<input type="checkbox"/>	<input type="checkbox"/>	<input type="checkbox"/>	<input type="checkbox"/>	<input type="checkbox"/>	<input type="checkbox"/>	<input type="checkbox"/>	<input type="checkbox"/>
G. Another method allowed by DENR. Please specify.	_____	_____	_____	_____	_____	_____	_____	_____	_____	_____
2. Release Detection (Mark all that apply)	TANK	PIPING	TANK	PIPING	TANK	PIPING	TANK	PIPING	TANK	PIPING
A. Manual tank gauging	<input type="checkbox"/>		<input type="checkbox"/>		<input type="checkbox"/>		<input type="checkbox"/>		<input type="checkbox"/>	
B. Tank tightness testing	<input type="checkbox"/>		<input type="checkbox"/>		<input type="checkbox"/>		<input type="checkbox"/>		<input type="checkbox"/>	
C. Inventory Controls	<input type="checkbox"/>		<input type="checkbox"/>		<input type="checkbox"/>		<input type="checkbox"/>		<input type="checkbox"/>	
D. Automatic tank gauging	<input type="checkbox"/>		<input type="checkbox"/>		<input type="checkbox"/>		<input type="checkbox"/>		<input type="checkbox"/>	<input type="checkbox"/>
E. Vapor monitoring	<input type="checkbox"/>	<input type="checkbox"/>	<input type="checkbox"/>	<input type="checkbox"/>	<input type="checkbox"/>	<input type="checkbox"/>	<input type="checkbox"/>	<input type="checkbox"/>	<input type="checkbox"/>	<input type="checkbox"/>
F. Groundwater monitoring	<input type="checkbox"/>	<input type="checkbox"/>	<input type="checkbox"/>	<input type="checkbox"/>	<input type="checkbox"/>	<input type="checkbox"/>	<input type="checkbox"/>	<input type="checkbox"/>	<input type="checkbox"/>	<input type="checkbox"/>
G. Interstitial monitoring/secondary containment	<input type="checkbox"/>	<input type="checkbox"/>	<input type="checkbox"/>	<input type="checkbox"/>	<input type="checkbox"/>	<input type="checkbox"/>	<input type="checkbox"/>	<input type="checkbox"/>	<input type="checkbox"/>	<input type="checkbox"/>
H. Automatic line leak detectors	<input type="checkbox"/>	<input type="checkbox"/>	<input type="checkbox"/>	<input type="checkbox"/>	<input type="checkbox"/>	<input type="checkbox"/>	<input type="checkbox"/>	<input type="checkbox"/>	<input type="checkbox"/>	<input type="checkbox"/>
I. Line tightness testing	<input type="checkbox"/>	<input type="checkbox"/>	<input type="checkbox"/>	<input type="checkbox"/>	<input type="checkbox"/>	<input type="checkbox"/>	<input type="checkbox"/>	<input type="checkbox"/>	<input type="checkbox"/>	<input type="checkbox"/>
J. Other method allowed by DENR.	<input type="checkbox"/>	<input type="checkbox"/>	<input type="checkbox"/>	<input type="checkbox"/>	<input type="checkbox"/>	<input type="checkbox"/>	<input type="checkbox"/>	<input type="checkbox"/>	<input type="checkbox"/>	<input type="checkbox"/>
Please specify	_____	_____	_____	_____	_____	_____	_____	_____	_____	_____
3. Spill and Overfill Protection										
A. Overfill device installed	<input type="checkbox"/>	<input type="checkbox"/>	<input type="checkbox"/>	<input type="checkbox"/>	<input type="checkbox"/>	<input type="checkbox"/>	<input type="checkbox"/>	<input type="checkbox"/>	<input type="checkbox"/>	<input type="checkbox"/>
Please specify	_____	_____	_____	_____	_____	_____	_____	_____	_____	_____
B. Spill device installed	<input type="checkbox"/>	<input type="checkbox"/>	<input type="checkbox"/>	<input type="checkbox"/>	<input type="checkbox"/>	<input type="checkbox"/>	<input type="checkbox"/>	<input type="checkbox"/>	<input type="checkbox"/>	<input type="checkbox"/>

OATH: I certify the information concerning installation that is provided in section XI is true to the best of my belief and knowledge.

Installer: _____

Name

Signature

Date

Position

Company

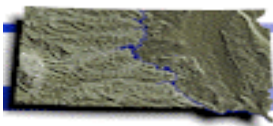

Change of Ownership Notification Form

GENERAL INFORMATION

STATE USE ONLY

State and Federal laws require notification of any changes in the information contained on a notification form within 30-days after the change. Person who acquires ownership of a UST/AST system shall notify DENR of the change within 30-days.

Where To Notify? Send completed forms to:
Ground Water Quality Program, Storage Tank Section
 523 East Capitol, Pierre, SD 57501
 Phone # (605) 773-3296, Fax # (605) 773-6035
www.state.sd.us/denr/DES/ground/tanks/TankSection.htm

FACILITY ID NUMBER:

DATE RECEIVED:

A. Date Entered into Computer

B. Data Entry Clerk Initials

Facility - Location (Do Not Use P.O. Box)

New Owner

Name (Corporation, Individual, Public Agency, or Other Entity)

Name (Corporation, Individual, Public Agency, or Other Entity)

Street Address

Street Address

City

State

Zip Code

City

state

Zip Code

County

County

Phone Number (include Area Code)

Phone Number (include Area Code)

DENR Facility ID Number

Facility Type (underground UST/aboveground AST)

Previous Owner

New Owner Invoice Mailing Address (If different)

Name _____

Name _____

Address _____

Address _____

City _____

City _____

State/Zip _____

State/Zip _____

Phone _____

Phone _____

Fax _____

Fax _____

Certification: I certify that the following is true and accurate: (please check all that apply)

- I am familiar with the Administrative Rules of South Dakota Chapter 74:56:01, regarding UST requirements.
- I am familiar with the Administrative Rules of South Dakota Chapter 74:56:03, regarding AST requirements.

Notice Submitted By: [] Owner [] Operator [] Other:

 (Please print name)

 (Title)

 (Date)

 (Phone)

 (Fax)

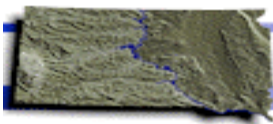

Regulated Storage Tank Removal Notification Form

GENERAL INFORMATION

STATE USE ONLY

If an UST system is taken out of service for longer than 12 months and if an AST system taken out of service for longer than 24 months, it shall be permanently closed. State and Federal laws require notification at least 30 days before permanent closure. If more than five (5) tanks are owned at this location, photocopy this form, and staple the photocopy to the original form.

Where To Notify? Send completed forms to:
 Ground Water Quality Program, Storage Tank Section
 523 East Capitol, Pierre, SD 57501
 Phone # (605) 773-3296, Fax # (605) 773-6035
 www.state.sd.us/DENR

FACILITY ID NUMBER: _____

DATE RECEIVED: _____

A. Date Entered into Computer _____

B. Data Entry Clerk Initials _____

C. Date Faxed to PRCF _____

I. OWNERSHIP OF TANK(S)

II. LOCATION OF TANK(S)

Owner Name (Corporation, Individual, Public Agency, or Other Entity) _____

If known, give the geographic location of tanks by degrees, minutes, and seconds.
 Examples Lat. 42, 36, 12 N Long. 85, 24, 17 W

Latitude _____ **Longitude** _____

Street Address _____

Facility Name _____

(if same as Section I, mark box here)



Street Address _____

City _____

State _____

Zip Code _____

County _____

City _____

State _____

Zip Code _____

Phone Number (include Area Code) _____

County _____

Phone Number (include Area Code) _____

Tank Identification Number

Tank No. 1

Tank No. 2

Tank No. 3

Tank No. 4

Tank No. 5

UST (underground) or AST (aboveground) Tank

Capacity _____

Date Last Use _____

Type of Fuel Stored _____

Will this tank system be replaced ? If yes, Describe

Have plans been approved by DENR

Scheduled removal date

Has pre-removal assessment been performed ?

Date performed

Name of Environmental Consultant to be present during removal _____

Name of State or Local Official to be Present _____

Volume of tank bottoms _____ **Volume of Product** _____ **Volume of Water** _____

(sludge)

Disposal of tank, tank bottoms, and water _____

Note: Wastes must be appropriately identified, determine if they exhibit hazardous characteristics and be disposed of properly. Tanks not recycled or salvaged must also be disposed of properly. Receipts or waste manifests may be required by the DENR Waste Management Program upon disposal. Please call (605) 773-3153 for questions regarding the waste disposal.

Form completed by _____ **Date** _____

GAS STATIONS

Do Your Part to Protect Our Environment



Underground Storage Tanks

- Perform required periodic tests: line tightness, line leak detector, and cathodic protection, if applicable.
- Organize and maintain records of release detection, periodic tests, financial responsibility.
- Perform regular walk-through inspections of your facility. Look at sumps, piping, hoses for any leaks.

Aboveground Storage Tanks

- Develop and implement an SPCC plan.
- Provide secondary containment and proper security.
- Routinely monitor for leaks.



Used Oil

- Store used oil in containers that are in good condition.
- Clearly label containers as "USED OIL."
- Do not mix other fluids or waste with used oil.
- Clean up any spills or leaks.

Motor Vehicle Waste Disposal Wells

- Notify EPA and your local authority about any existing Motor Vehicle Waste Disposal Wells (these wells may be prohibited.)
- Provide well inventory information to EPA and your local authority.
- Do not create any new Motor Vehicle Waste Disposal Wells.



Air Conditioning Units

- Technician and facility must be certified by an EPA-approved testing organization.
- Do not vent and release CFCs into the atmosphere. They must be recovered during servicing.



If you have any further questions, please contact the
South Dakota Department of Environment and Natural Resources,
Ground Water Quality Program, Storage Tank Section. Pierre (605) 773-3296,
Rapid City (605) 394-2229
or Sioux Falls (605) 362-3500